

# WEIDERPRO™

## 490 DC

Model No. WEEVBE29711.0

Serial No. \_\_\_\_\_

Write the serial number in the space above for reference.

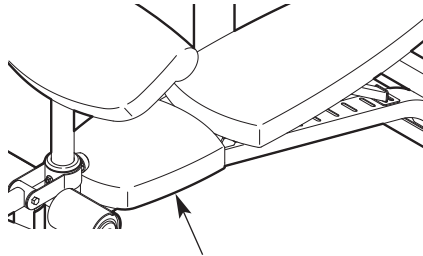

Serial Number Decal  
(under the seat)

## USER'S MANUAL

### QUESTIONS?

If you have questions, or if there are missing parts, please contact us:

#### UK

Call: 08457 089 009

From Ireland: 053 92 36102

Website: [www.iconsupport.eu](http://www.iconsupport.eu)

E-mail: [csuk@iconeurope.com](mailto:csuk@iconeurope.com)

#### Write:

ICON Health & Fitness, Ltd.

c/o HI Group PLC

Express Way

Whitwood, West Yorkshire

WF10 5QJ

UK

#### AUSTRALIA

Call: 1-800-237-173

E-mail:

[australiacc@iconfitness.com](mailto:australiacc@iconfitness.com)

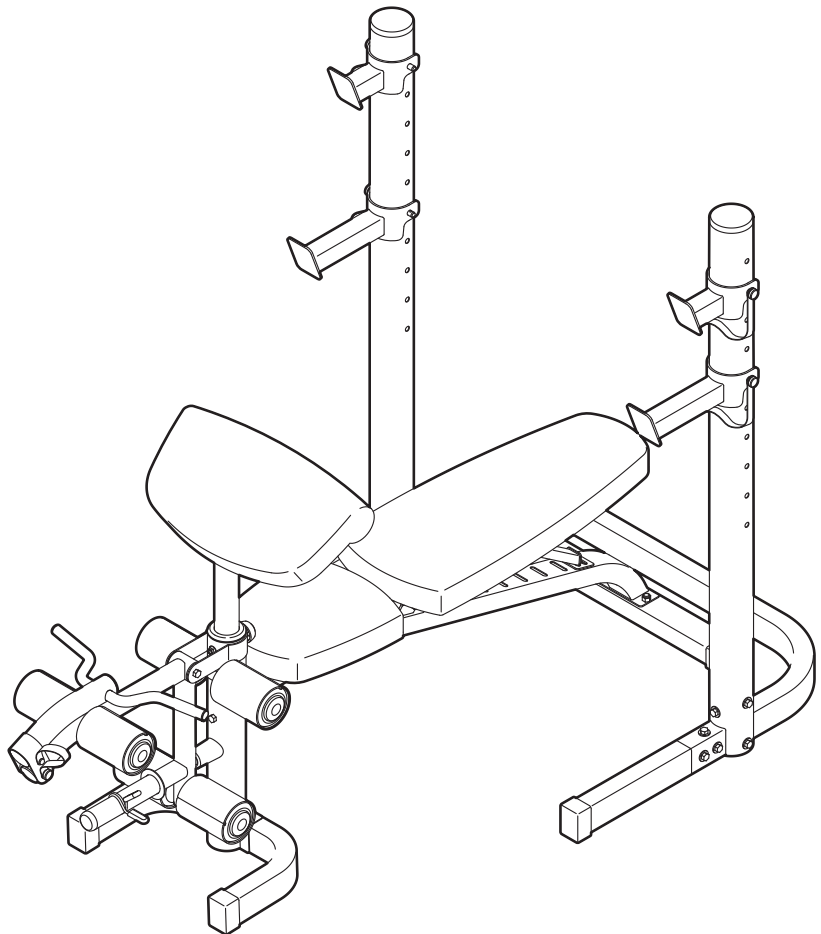

### ⚠ CAUTION

Read all precautions and instructions in this manual before using this equipment. Save this manual for future reference.

# TABLE OF CONTENTS

WARNING DECAL PLACEMENT .....2

IMPORTANT PRECAUTIONS .....3

BEFORE YOU BEGIN .....4

PART IDENTIFICATION CHART .....5

ASSEMBLY .....6

ADJUSTMENT .....13

EXERCISE GUIDELINES .....15

PART LIST .....17

EXPLODED DRAWING .....18

ORDERING REPLACEMENT PARTS .....Back Cover

## WARNING DECAL PLACEMENT

This drawing shows the location(s) of the warning decal(s).  
**If a decal is missing or illegible, see the front cover of this manual and request a free replacement decal.**  
**Apply the decal in the location shown.** Note: The decal(s) may not be shown at actual size.

**⚠ WARNING**

- Misuse of this machine may result in serious injury.
- Read user's manual prior to use and follow all warnings and instructions.
- Do not allow children on or around machine.
- Keep body, clothing, and hair free and clear of all moving parts.
- Replace label if damaged, illegible, or removed.

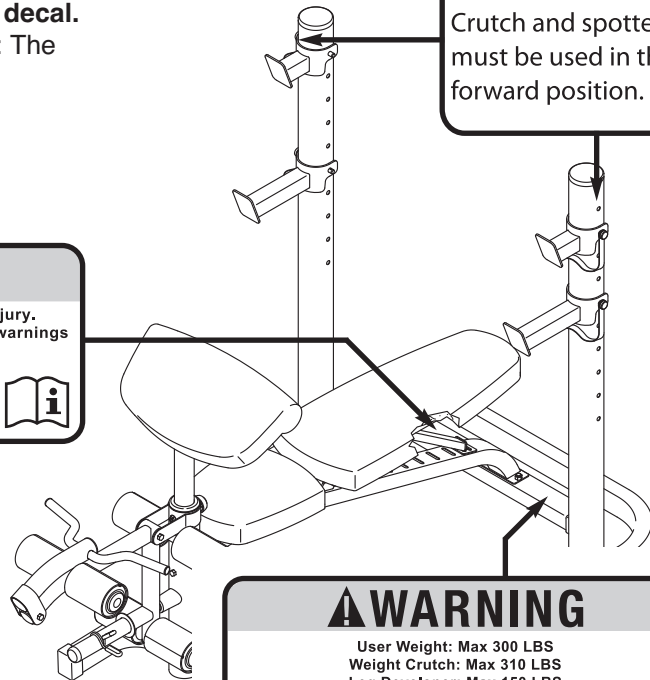
**⚠ WARNING**

Crutch and spotters must be used in the forward position.

**⚠ WARNING**

User Weight: Max 300 LBS  
 Weight Crutch: Max 310 LBS  
 Leg Developer: Max 150 LBS  
 Weight Carriage: Max 150 LBS  
 Chest Fly Per Arm: Max 50 LBS

Product may not offer all listed exercises.

# IMPORTANT PRECAUTIONS

**⚠️ WARNING:** To reduce the risk of serious injury, read all important precautions and instructions in this manual and all warnings on your weight bench before using your weight bench. ICON assumes no responsibility for personal injury or property damage sustained by or through the use of this product.

1. Before beginning any exercise program, consult your physician. This is especially important for persons over age 35 or persons with pre-existing health problems.
2. Use the weight bench only as described in this manual.
3. It is the responsibility of the owner to ensure that all users of the weight bench are adequately informed of all precautions.
4. The weight bench is intended for home use only. Do not use the weight bench in a commercial, rental, or institutional setting.
5. Keep the weight bench indoors, away from moisture and dust. Do not put the weight bench in a garage or covered patio, or near water.
6. Place the weight bench on a level surface, with a mat beneath it to protect the floor or carpet. Make sure that there is enough clearance around the weight bench to mount, dismount, and use it.
7. Inspect and properly tighten all parts regularly. Replace any worn parts immediately.
8. The weight bench is designed to support a maximum user weight of 300 lbs. (136 kg) and a maximum total weight of 610 lbs. (277 kg). Do not place more than 310 lbs. (141 kg), including a barbell, on the weight rests.  
  
Do not place more than 150 lbs (68 kg) on the leg lever. Note: The weight bench does not include a barbell or weights.
9. Always keep children under age 12 and pets away from the weight bench.
10. Wear appropriate clothes while exercising; do not wear loose clothes that could become caught on the weight bench. Wear athletic shoes for foot protection while exercising.
11. Always keep hands and feet away from moving parts.
12. Before you use the weight bench, make sure that the backrest brace is fully inserted into a slot in the frame.
13. Before you use the weight rests and the spotters, make sure that the large pins are fully inserted through the weight rests or the spotters and through the uprights.
14. Do not use a barbell that is longer than 6 ft. (1.8 m) with the weight bench.
15. Always exercise with a partner. When you perform the bench press exercise, your partner should stand behind you to catch the barbell if you cannot complete a repetition.
16. Over exercising may result in serious injury or death. If you feel faint or if you experience pain while exercising, stop immediately and cool down.

# BEFORE YOU BEGIN

Thank you for selecting the versatile WEIDER PRO™ 490 DC Olympic weight bench. The 490 DC Olympic weight bench offers a selection of exercise stations designed to develop the major muscle groups of the body. Whether your goal is to tone your body, build dramatic muscle size and strength, or improve your cardiovascular system, the weight bench will help you to achieve the specific results you want.

**For your benefit, read this manual carefully before using the weight bench.** If you have questions after

reading this manual, please see the back cover of this manual. To help us assist you, note the product model number and serial number before contacting us. The model number and the location of the serial number decal are shown on the front cover of this manual.

Before reading further, please review the drawing below and familiarize yourself with the parts that are labeled.

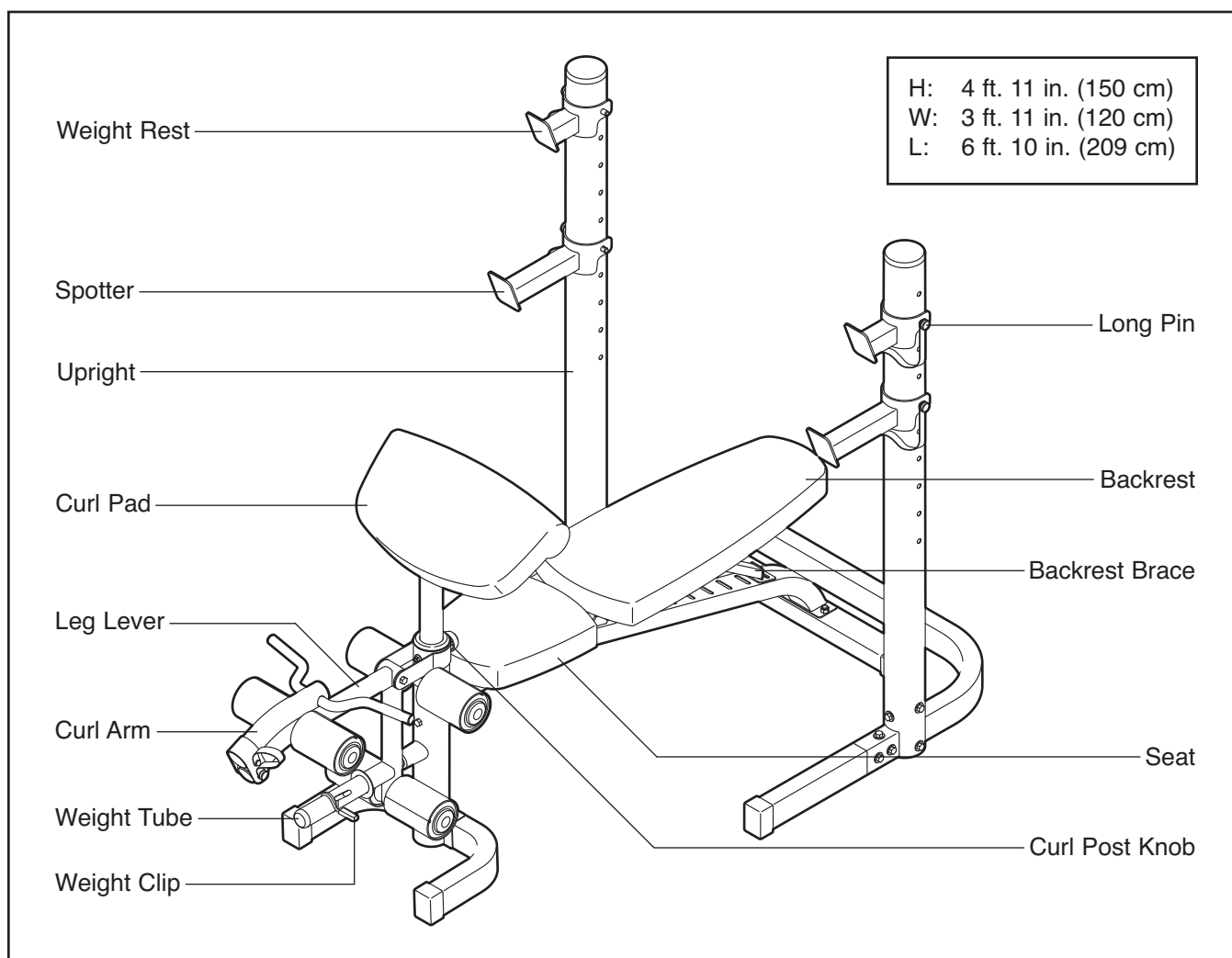

# PART IDENTIFICATION CHART

See the drawings below to identify small parts used in assembly. The number in parentheses by each drawing is the key number of the part, from the PART LIST near the end of this manual. **Note: If a part is not in the hardware kit, check to see if it has been preattached. To avoid damaging parts, do not use power tools for assembly.**

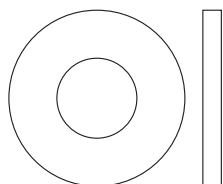

M10 Washer (35)-29

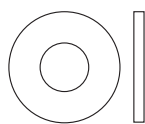

M6 Washer (42)-4

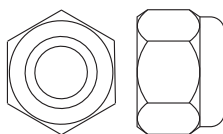

M10 Locknut (37)-10



M6 x 16mm Screw (39)-6

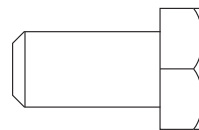

M10 x 20mm Screw (34)-18

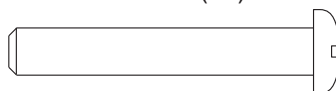

M6 x 40mm Screw (41)-4

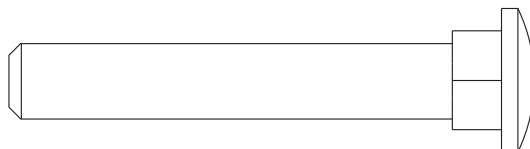

M10 x 65mm Carriage Bolt (40)-2

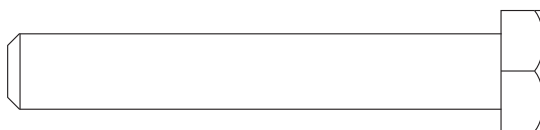

M10 x 65mm Screw (36)-1

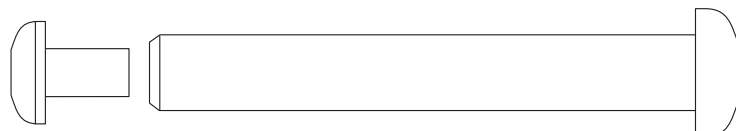

M10 x 73mm Bolt Set (45)-1

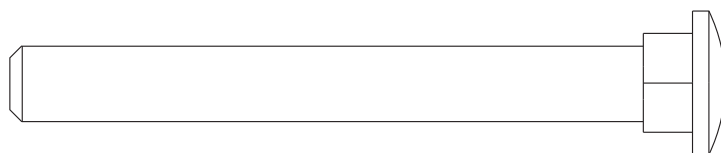

M10 x 90mm Carriage Bolt (55)-2

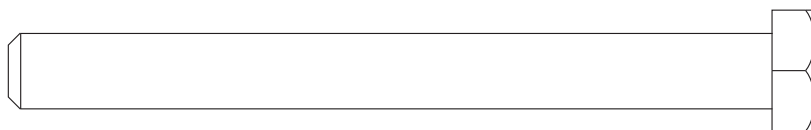

M10 x 100mm Bolt (38)-2

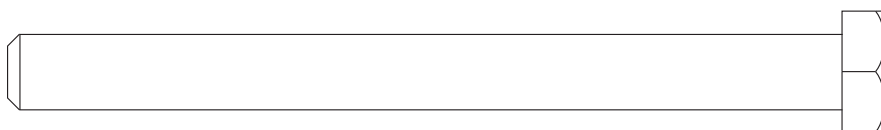

M10 x 110mm Bolt (44)-2



M10 x 180mm Bolt (54)-1



M10 x 195mm Bolt (43)-1

# ASSEMBLY

- Assembly requires two persons.
- Because of its size and weight, assemble the weight bench in the location where it will be used. Make sure that there is enough clearance to walk around the weight bench as you assemble it.
- Place all parts in a cleared area and remove the packing materials. Do not dispose of the packing materials until you complete all assembly steps.
- To identify small parts, see page 5.

- The following tools (not included) may be required for assembly:

two adjustable wrenches 

one standard screwdriver 

one Phillips screwdriver 

Assembly will be more convenient if you have a socket set, a set of open-end or closed-end wrenches, or a set of ratchet wrenches.

1. **To make assembly easier, read the tips at the top of this page before you begin.**

Orient the Front Stabilizer (2) so that the square holes are facing the floor.

Attach the Front Leg (4) to the Front Stabilizer (2) with two M10 x 90mm Carriage Bolts (55) and two M10 Locknuts (37). **Do not tighten the Locknuts yet.**

Then, tighten an M10 x 65mm Screw (36) with an M10 Washer (35) into the Front Stabilizer (2) and the Front Leg (4). **Do not tighten the Screw yet.**

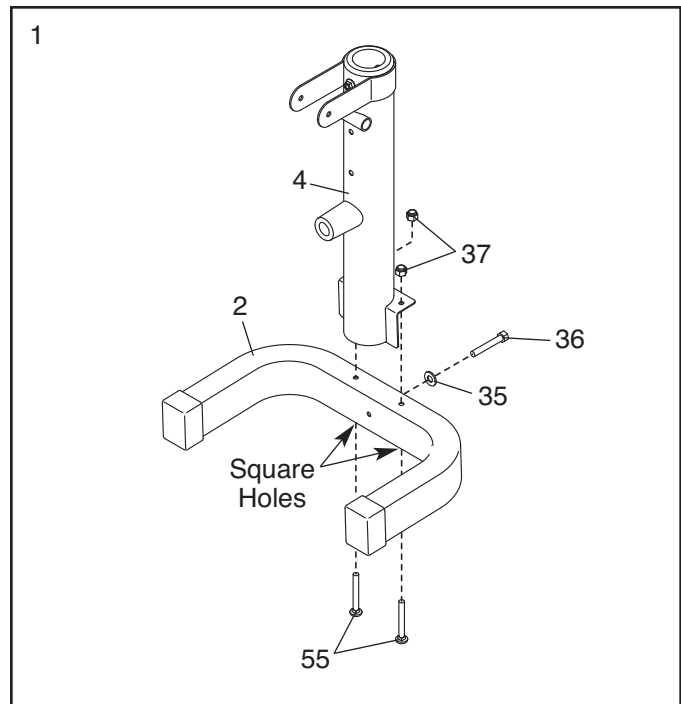

2. Attach the Front Leg (4) to the Frame (1) with two M10 x 100mm Bolts (38), two M10 Washers (35), and two M10 Locknuts (37). **Do not tighten the Locknuts yet.**

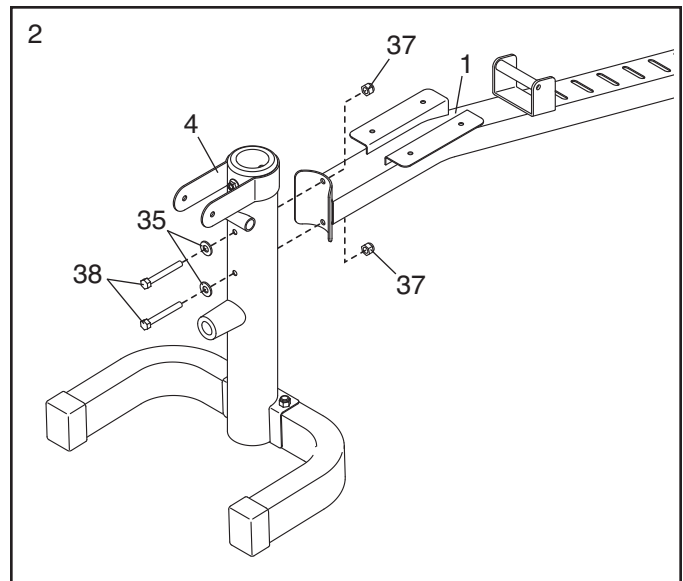

3. Orient the Rear Stabilizer (3) so that the warning decals are facing upward.

Attach the Rear Stabilizer (3) to the Frame (1) with two M10 x 65mm Carriage Bolts (40) and two M10 Locknuts (37).

**See step 1. Tighten the M10 Locknuts (37) and the M10 x 65mm Screw (36).**

**See step 2. Tighten the M10 Locknuts (37).**

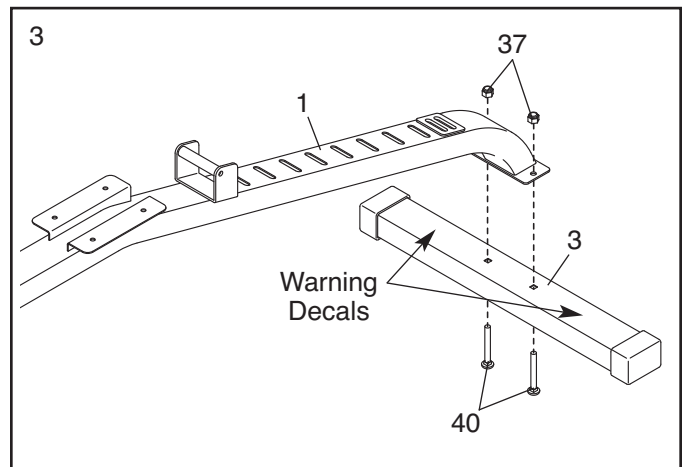

4. Orient the Seat (18) as shown.

Attach the Seat (18) to the Frame (1) with four M6 x 16mm Screws (39).

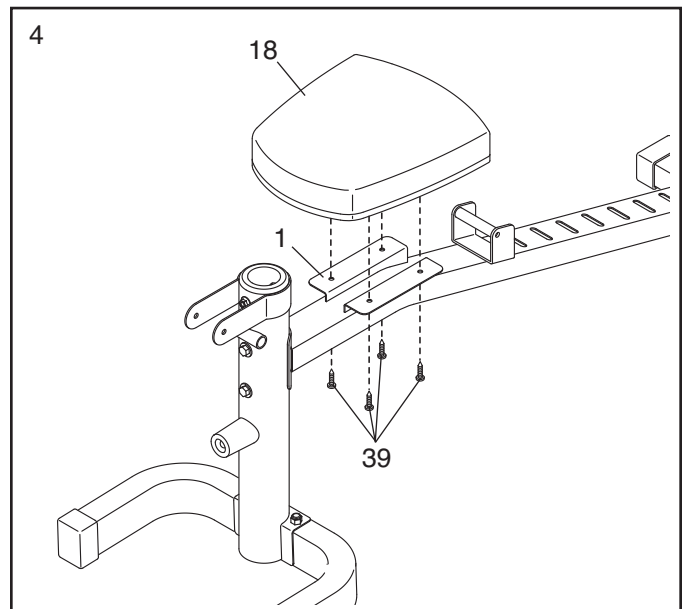

5. Orient the Backrest Frames (16) so that the welded tubes are in the positions shown.

Apply a small amount of the included grease to an M10 x 180mm Bolt (54). Attach the Backrest Brace (15) to the Backrest Frames (16) with the Bolt, two M10 Washers (35), and an M10 Locknut (37). **Do not tighten the Locknut yet.**

Orient the Backrest (19) as shown.

Attach the Backrest (19) to the Backrest Frames (16) with four M6 x 40mm Screws (41) and four M6 Washers (42). **Do not tighten the Screws yet.**

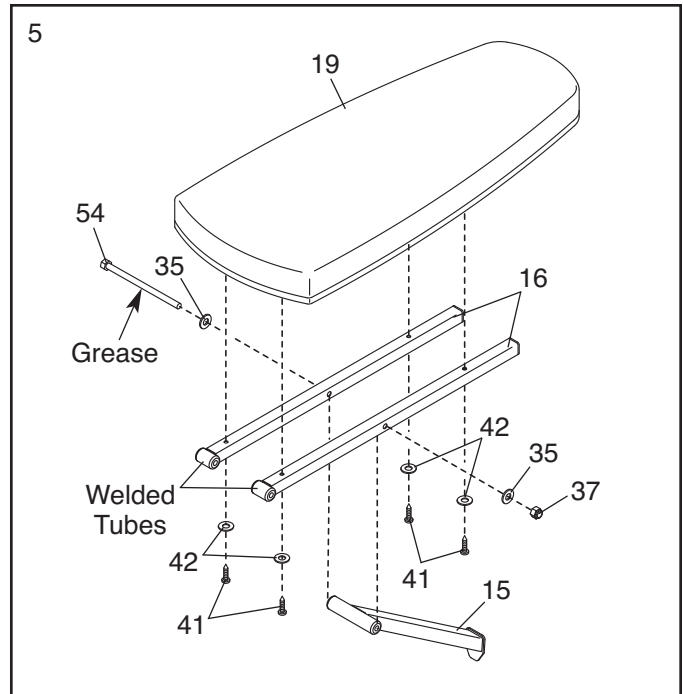

6. Apply a small amount of grease to an M10 x 195mm Bolt (43). Attach the Backrest Frames (16) to the Frame (1) with the Bolt, two M10 Washers (35), and an M10 Locknut (37). **Do not overtighten the Locknut; the Backrest Frames should pivot easily.**

Insert the end of the Backrest Brace (15) into one of the slots in the Frame (1).

**See step 5. Tighten the four M6 x 40mm Screws (41) and the M10 Locknut (37). Do not overtighten the Locknut; the Backrest Brace (15) should pivot easily.**

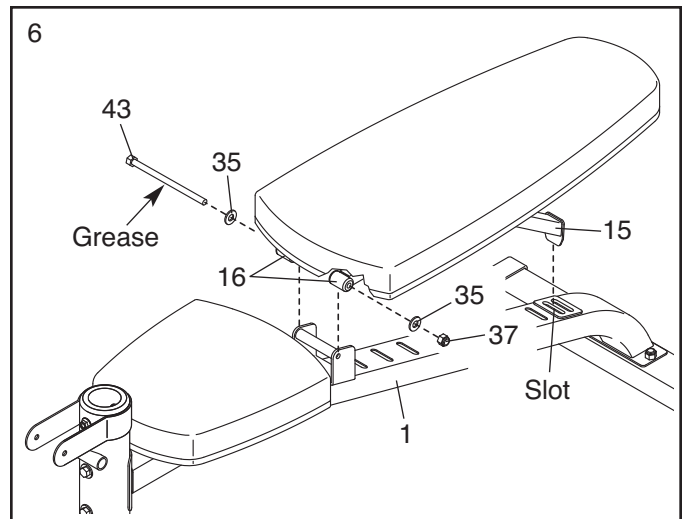

7. Apply a small amount of grease to the barrel of an M10 x 73mm Bolt Set (45). Attach the Leg Lever (5) to the Front Leg (4) with the Bolt Set. **Make sure that the barrel of the Bolt Set is inserted through both sides of the bracket on the Front Leg.**

Then, attach the Weight Clip (8) to the weight tube on the Leg Lever (5).

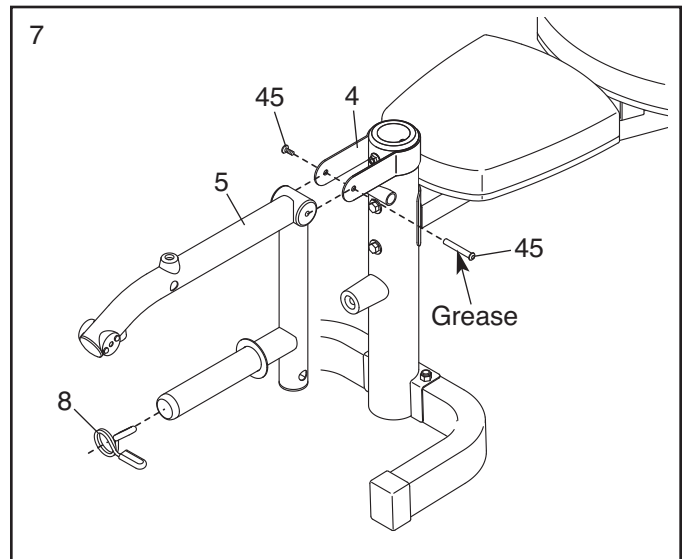



8. Insert the Long Pad Tube (31) through the Front Leg (4).

Slide two Foam Pads (22) onto the Long Pad Tube (31). Then, press two Pad Caps (23) into the ends of the Long Pad Tube.

**Attach the two Short Pad Tubes (not shown) and the remaining Foam Pads (22) and Pad Caps (23) to the Leg Lever (5) in the same way.**

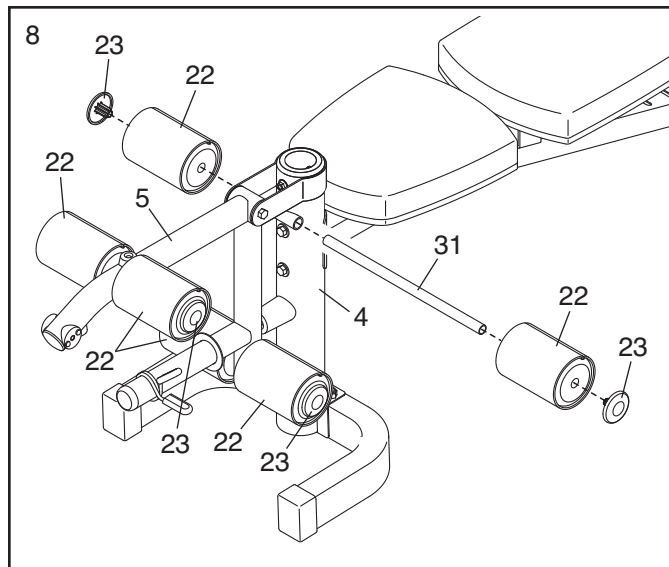

9. Slide the Curl Arm (50) downward over the Curl Arm Bushings (47). Then, insert the Small Pin (52) through the Curl Arm, the Curl Arm Bushings, and the Leg Lever (5).

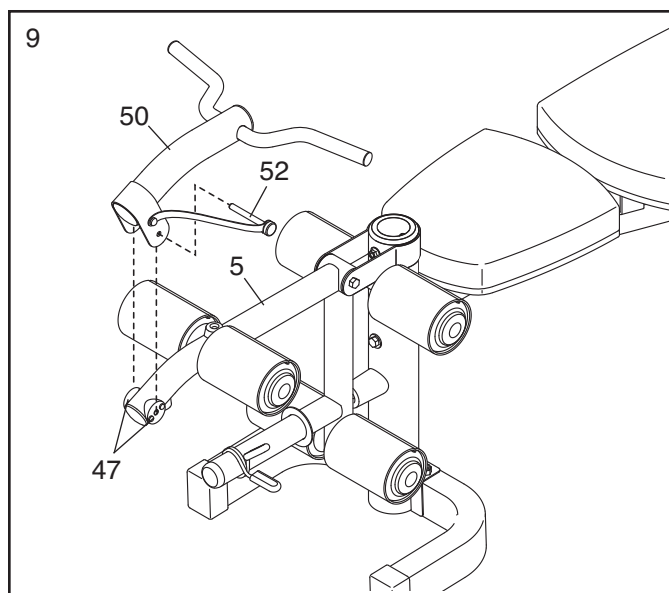

10. Attach the Curl Pad (20) to the Curl Post (6) with two M6 x 16mm Screws (39).

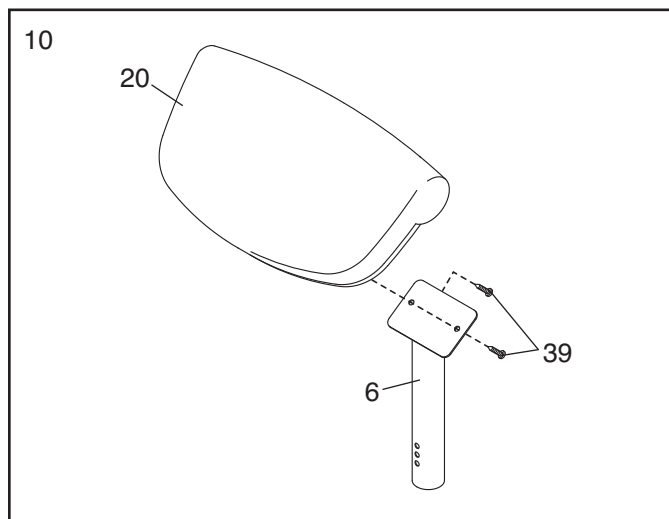

11. Insert the Curl Post (6) into the Front Leg (4).

Insert the Curl Post Knob (24) into the Front Leg (4) and into one of the adjustment holes in the Curl Post (6), and tighten the Curl Post Knob. **Make sure that the Curl Post Knob is inserted through one of the adjustment holes.**

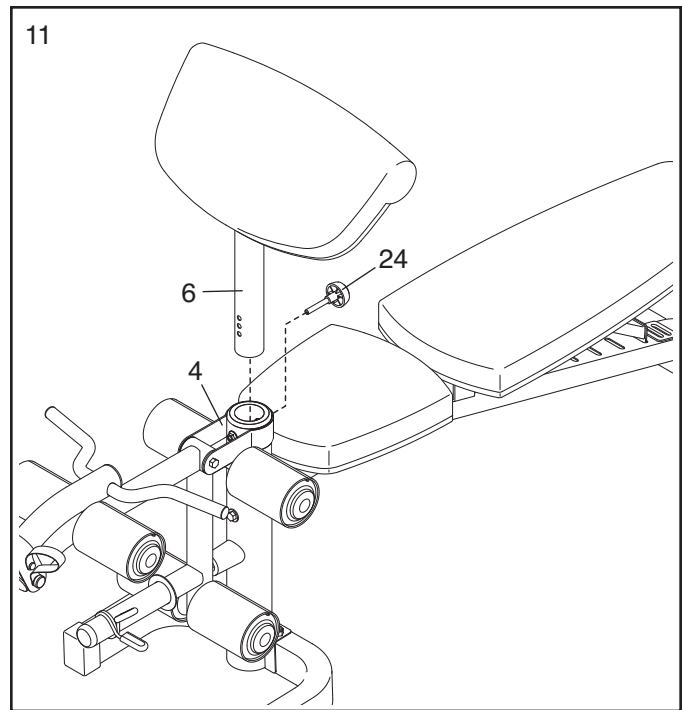

12. Insert a Base Stabilizer (9) into the Base (7).  
Attach the Base Stabilizer with five M10 x 20mm Screws (34) and five M10 Washers (35).

**Attach the other Base Stabilizer (9) to the Base (7) in the same way.**

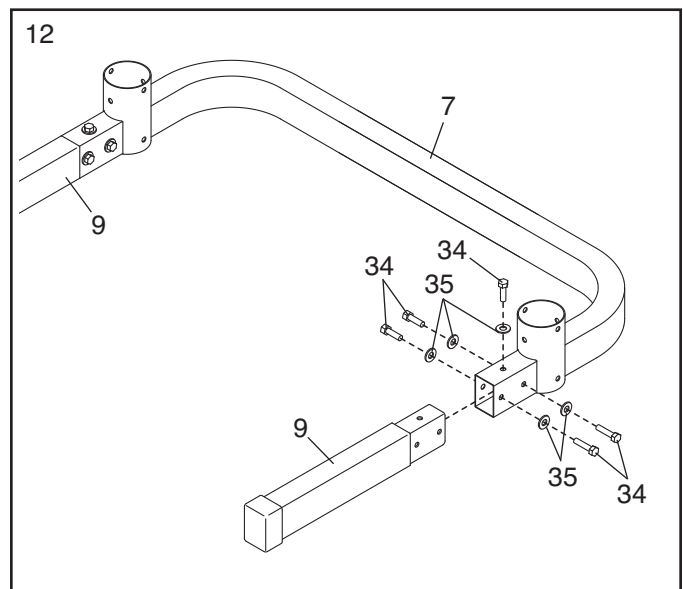

13. Slide one of the Uprights (11) onto the Base (7). Attach the Upright with an M10 x 110mm Bolt (44), four M10 x 20mm Screws (34), six M10 Washers (35), and an M10 Locknut (37).

**Attach the other Upright (11) to the Base (7) in the same way.**

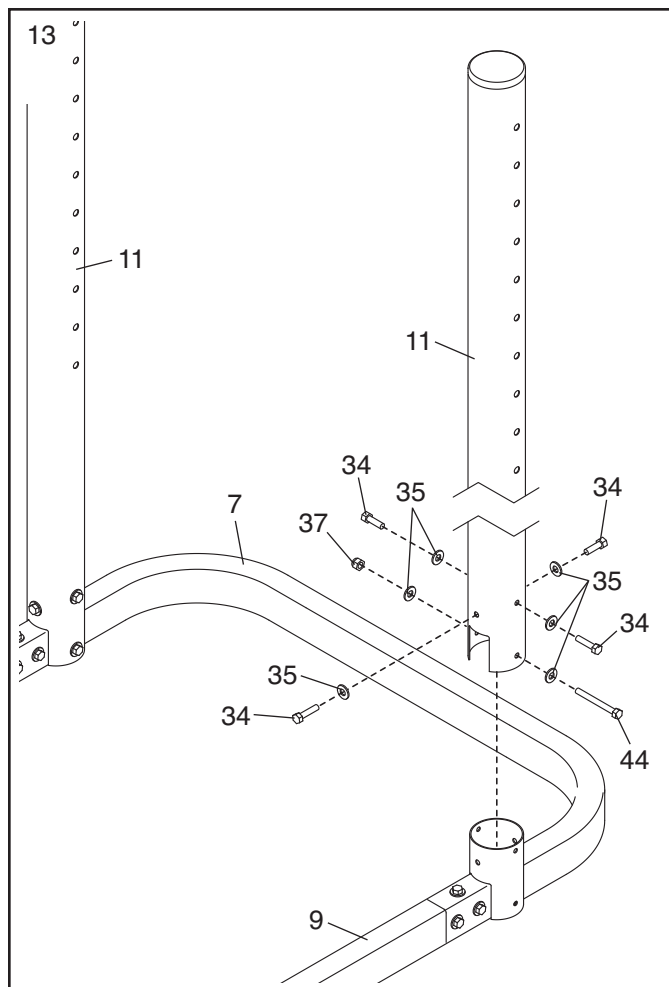

14. Hold a Weight Rest (12) on the indicated side of an Upright (11), and align the Weight Rest with one of the adjustment holes in the Upright. Insert the Large Pin (13) through the Weight Rest and the Upright.

**Attach the other Weight Rest (not shown) to the other Upright (11) in the same way. Attach both Weight Rests at the same height.**

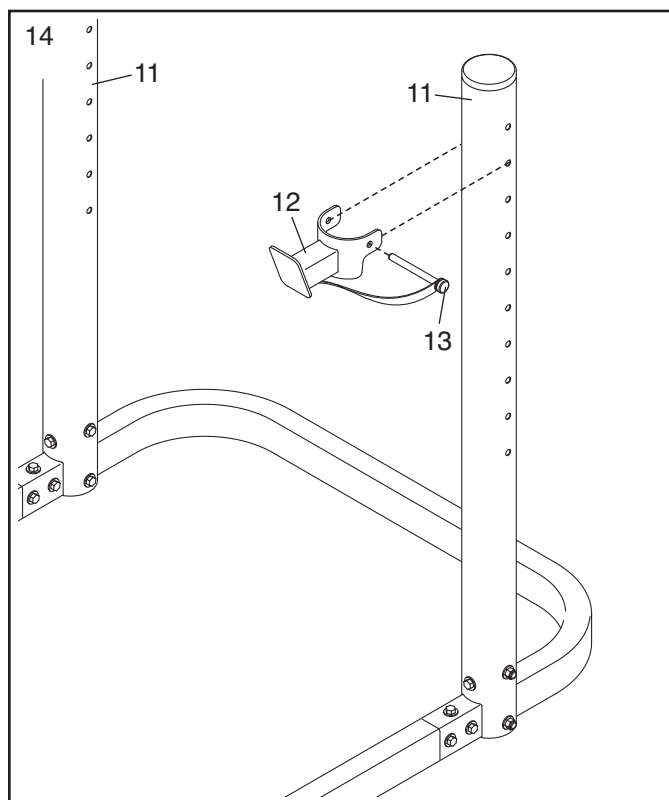

15. Hold a Spotter (29) **on the indicated side** of an Upright (11), and align the Spotter with one of the adjustment holes in the Upright. Insert the Large Pin (13) through the Spotter and the Upright.

**Attach the other Spotter (29) to the other Upright (11) in the same way. Attach both Spotters at the same height.**

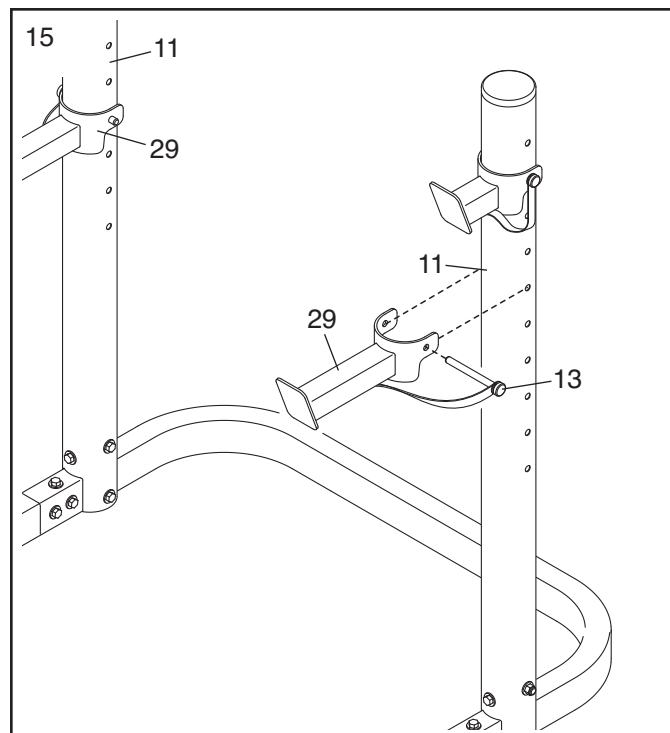

16. Make sure that all parts are properly tightened before you use the weight bench.

# ADJUSTMENT

This section explains how to adjust the weight bench. See the EXERCISE GUIDELINES on page 15 for important information about how to get the most benefit from your exercise program. Also, refer to the accompanying exercise guide to see the correct form for several exercises.

Make sure that all parts are properly tightened each time you use the weight bench. Replace any worn parts immediately. To clean the weight bench, use a damp cloth and a mild, non-abrasive detergent; **do not use solvents.**

## ADJUSTING THE BACKREST

To change the angle of the Backrest (19), lift the Backrest and insert the Backrest Brace (15) into a different slot in the Frame (1).

**⚠ WARNING:** Make sure that the Backrest Brace (15) is fully inserted into a slot on the Frame (1).

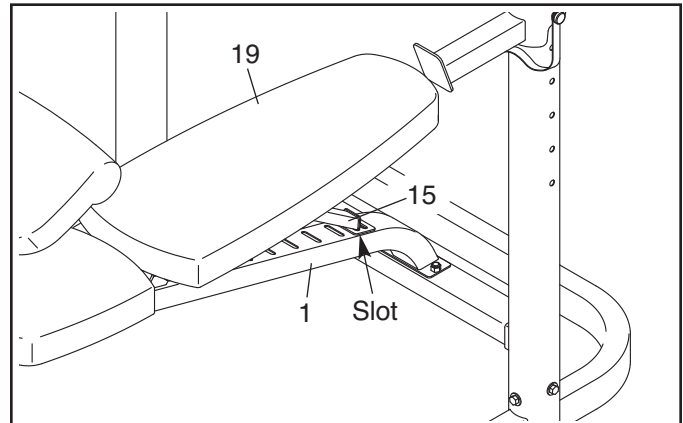

## USING THE LEG LEVER

To use the Leg Lever (5), slide a weight plate (not included) onto the weight tube on the Leg Lever. Secure the weight plate with the Weight Clip (8).

**⚠ WARNING:** Do not place more than 150 lbs. (68 kg) on the Leg Lever (5).

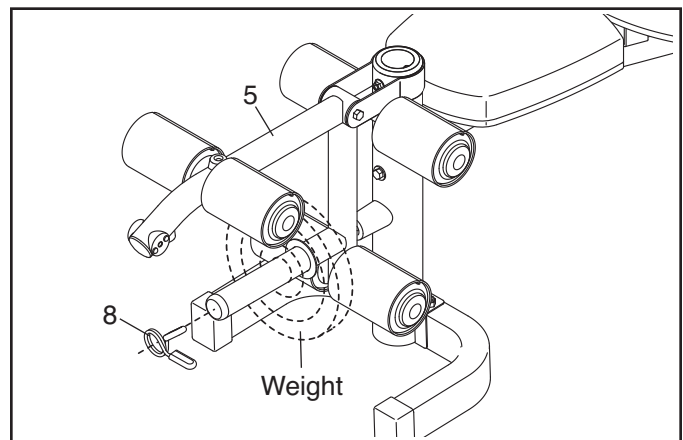

## USING THE CURL PAD

To use the Curl Pad (20), insert the Curl Post (6) into the Front Leg (4). Tighten the Curl Post Knob (24) into the Front Leg and into one of the adjustment holes in the Curl Post. **Make sure that the Curl Post Knob is inserted through one of the adjustment holes in the Curl Post.**

When performing exercises that do not require the Curl Pad (20), remove the Curl Post Knob (24) and the Curl Post (6).

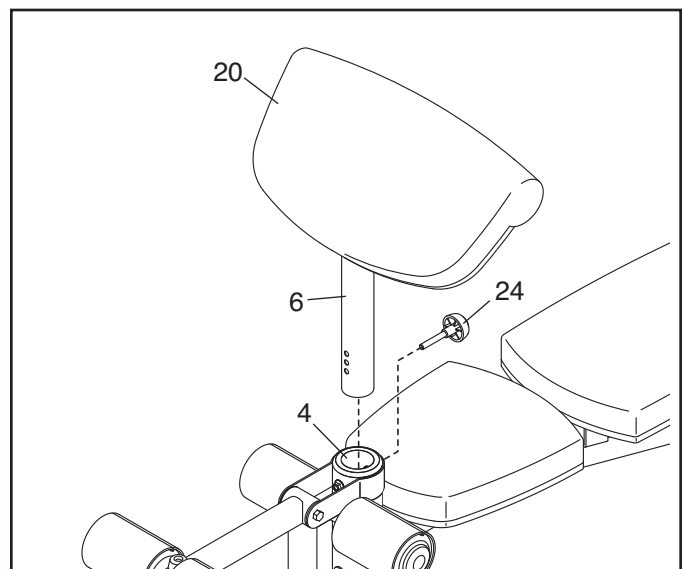

## USING THE CURL ARM

Slide the Curl Arm (50) downward over the Curl Arm Bushings (47). Then, insert the Small Pin (52) through the Curl Arm, the Curl Arm Bushings, and the Leg Lever (5).

When performing exercises that do not require the Curl Arm (50), remove it.

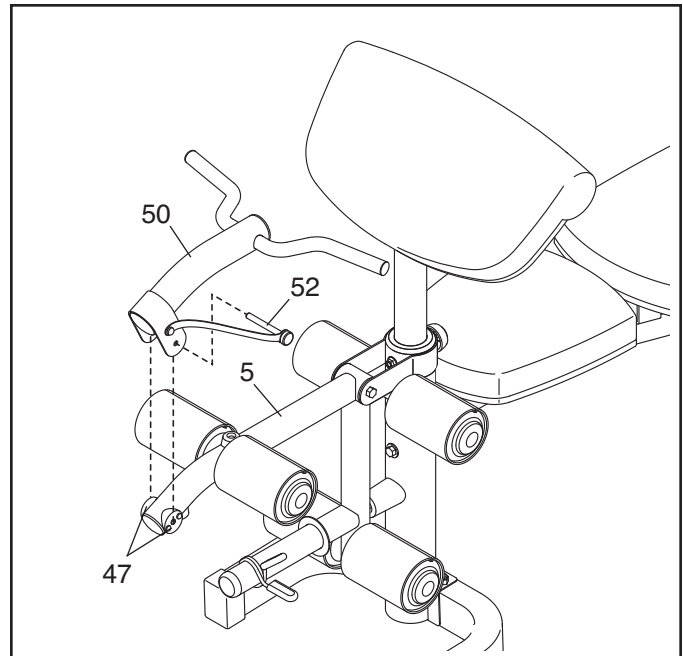

## ADJUSTING THE SPOTTERS AND THE WEIGHT RESTS

To adjust the height of the Spotters (29), first remove the Large Pins (13).

Hold a Spotter (29) **on the indicated side** of an Upright (11), and align the Spotter with the desired adjustment hole in the Upright. Insert a Large Pin (13) through the Spotter and the Upright. The Spotter should be attached at the lowest point to which you want your barbell to move when you perform the bench press exercise.

**Adjust the other Spotter (29) and the Weight Rests (12) in the same way.**

**⚠ WARNING:** Always attach the Spotters (29) and the Weight Rests (12) on the indicated side of the Uprights (11). Make sure that both Spotters are at the same height and that both Weight Rests are at the same height. In addition, make sure that the Large Pins (13) are fully inserted. Do not place more than 310 lbs. (141 kg), including a barbell, on the Weight Rests.

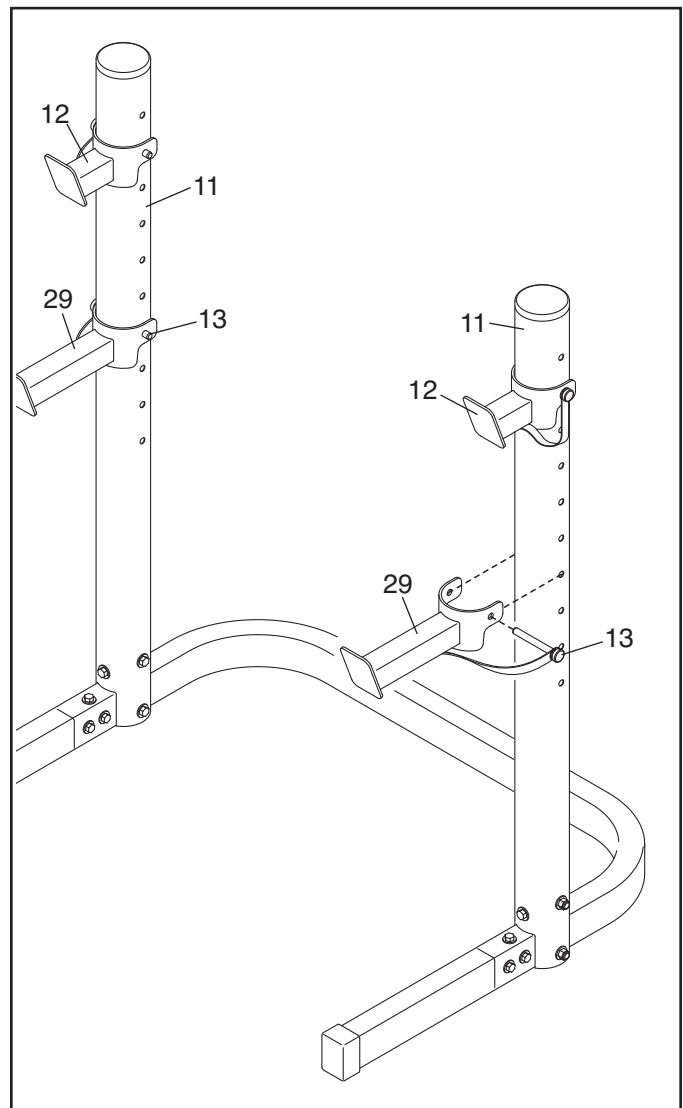

---

# EXERCISE GUIDELINES

## FOUR TYPES OF STRENGTH WORKOUTS

Note: A “repetition” is one complete cycle of an exercise, such as one sit-up. A “set” is a series of repetitions.

**Muscle Building**—Work your muscles near their maximum capacity and progressively increase the intensity of your exercise. Adjust the intensity level of an individual exercise as follows:

- Change the amount of resistance used.
- Change the number of repetitions or sets performed.

Use your own judgment to determine the amount of resistance that is right for you. Begin with 3 sets of 8 repetitions for each exercise that you perform. Rest for 3 minutes after each set. When you can complete 3 sets of 12 repetitions without difficulty, increase the amount of resistance.

**Toning**—Tone your muscles by working them to a moderate percentage of their capacity. Select a moderate amount of resistance and increase the number of repetitions in each set. Complete as many sets of 15 to 20 repetitions as possible without discomfort. Rest for 1 minute after each set. Work your muscles by completing more sets rather than by using high amounts of resistance.

**Weight Loss**—To lose weight, use a low amount of resistance and increase the number of repetitions in each set. Exercise for 20 to 30 minutes, resting for a maximum of 30 seconds between sets.

**Cross Training**—Combine strength training and aerobic exercise by following this type of program:

- Strength workouts on Monday, Wednesday, and Friday.
- 20 to 30 minutes of aerobic exercise on Tuesday and Thursday.
- One full day of rest each week to give your body time to regenerate.

## WORKOUT GUIDELINES

Familiarize yourself with the equipment and learn the proper form for each exercise. Use your own judgment

to determine the appropriate length of time for each workout, and the numbers of repetitions and sets to complete. Progress at your own pace and be sensitive to your body’s signals. Follow each strength workout with at least one day of rest.

**Warming Up**—Start with 5 to 10 minutes of stretching and light exercise. A warm-up increases your body temperature, heart rate, and circulation in preparation for exercise.

**Working Out**—Include 6 to 10 different exercises in each workout. Select exercises for every major muscle group, emphasizing areas that you want to develop. To give balance and variety to your workouts, vary the exercises from workout to workout.

**Cooling Down**—Finish with 5 to 10 minutes of stretching. Stretching increases the flexibility of your muscles and helps to prevent post-exercise problems.

## EXERCISE FORM

Move through the full range of motion for each exercise and move only the appropriate parts of the body. Perform the repetitions in each set smoothly and without pausing. The exertion stage of each repetition should last about half as long as the return stage. Exhale during the exertion stage of each repetition and inhale during the return stroke. Never hold your breath.

Rest for a short period of time after each set:

- Muscle Building—Rest for three minutes after each set.
- Toning—Rest for one minute after each set.
- Weight Loss—Rest for 30 seconds after each set.

## STAYING MOTIVATED

For motivation, keep a record of each workout. Write the date, the exercises performed, the resistance used, and the numbers of sets and repetitions completed. Record your weight and key body measurements once a month. To achieve good results, make exercise a regular and enjoyable part of your life.

## EXERCISE LOG

Make copies of this page, and use the copies to schedule and record your strength and aerobic workouts. Scheduling and recording your workouts will help you to make exercise a regular and enjoyable part of your life.

### Strength

Date:

\_\_\_\_ / \_\_\_\_ / \_\_\_\_

Exercise	Lbs.	Sets	Reps	Exercise	Lbs.	Sets	Reps
1.				6.			
2.				7.			
3.				8.			
4.				9.			
5.				10.			

### Aerobic

Date:

\_\_\_\_ / \_\_\_\_ / \_\_\_\_

Exercise	Time	Distance	Speed

### Strength

Date:

\_\_\_\_ / \_\_\_\_ / \_\_\_\_

Exercise	Lbs.	Sets	Reps	Exercise	Lbs.	Sets	Reps
1.				6.			
2.				7.			
3.				8.			
4.				9.			
5.				10.			

### Aerobic

Date:

\_\_\_\_ / \_\_\_\_ / \_\_\_\_

Exercise	Time	Distance	Speed

### Strength

Date:

\_\_\_\_ / \_\_\_\_ / \_\_\_\_

Exercise	Lbs.	Sets	Reps	Exercise	Lbs.	Sets	Reps
1.				6.			
2.				7.			
3.				8.			
4.				9.			
5.				10.			

### Aerobic

Date:

\_\_\_\_ / \_\_\_\_ / \_\_\_\_

Exercise	Time	Distance	Speed



# PART LIST

Model No. WEEVBE29711.0 R0311A

Key No.	Qty.	Description	Key No.	Qty.	Description
1	1	Frame	31	1	Long Pad Tube
2	1	Front Stabilizer	32	6	Backrest Frame Bushing
3	1	Rear Stabilizer	33	4	Foot
4	1	Front Leg	34	18	M10 x 20mm Screw
5	1	Leg Lever	35	29	M10 Washer
6	1	Curl Post	36	1	M10 x 65mm Screw
7	1	Base	37	10	M10 Locknut
8	1	Weight Clip	38	2	M10 x 100mm Bolt
9	2	Base Stabilizer	39	6	M6 x 16mm Screw
10	2	25mm Square Inner Cap	40	2	M10 x 65mm Carriage Bolt
11	2	Upright	41	4	M6 x 40mm Screw
12	2	Weight Rest	42	4	M6 Washer
13	4	Large Pin	43	1	M10 x 195mm Bolt
14	2	95mm Round Inner Cap	44	2	M10 x 110mm Bolt
15	1	Backrest Brace	45	1	M10 x 73mm Bolt Set
16	2	Backrest Frame	46	2	Curl Arm Bumper
17	9	ST4.2 x 16mm Screw	47	2	Curl Arm Bushing
18	1	Seat	48	6	Pad Cover
19	1	Backrest	49	1	Leg Lever Bumper
20	1	Curl Pad	50	1	Curl Arm
21	2	Short Pad Tube	51	2	25mm Round Inner Cap
22	6	Foam Pad	52	1	Small Pin
23	6	Pad Cap	53	3	ST4.2 x 25mm Screw
24	1	Curl Post Knob	54	1	M10 x 180mm Bolt
25	6	50mm x 75mm Outer Cap	55	2	M10 x 90mm Carriage Bolt
26	1	Curl Post Bushing	56	4	ST3.5 x 10mm Screw
27	2	Leg Lever Bushing	*	–	User's Manual
28	1	48mm Round Inner Cap	*	–	Exercise Guide
29	2	Spotter	*	–	Grease Packet
30	4	50mm Round Inner Cap			

Note: Specifications are subject to change without notice. For information about ordering replacement parts, see the back cover of this manual. \*These parts are not illustrated.

# EXPLODED DRAWING A

Model No. WEEVBE29711.0 R0311A

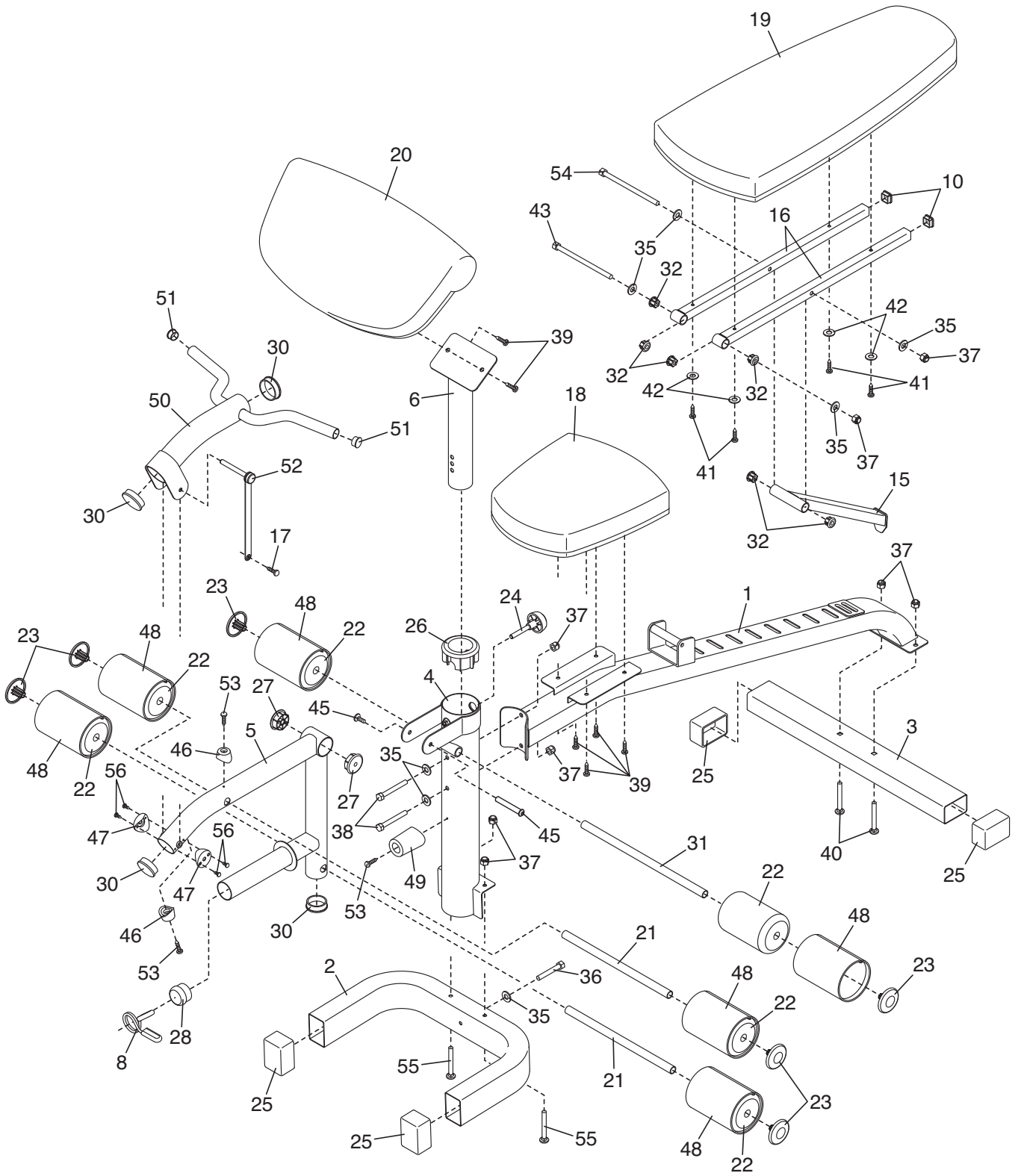

---

# ORDERING REPLACEMENT PARTS

To order replacement parts, please see the front cover of this manual. To help us assist you, be prepared to provide the following information when contacting us:

- the model number and serial number of the product (see the front cover of this manual)
- the name of the product (see the front cover of this manual)
- the key number and description of the replacement part(s) (see the PART LIST and the EXPLODED DRAWING near the end of this manual)