

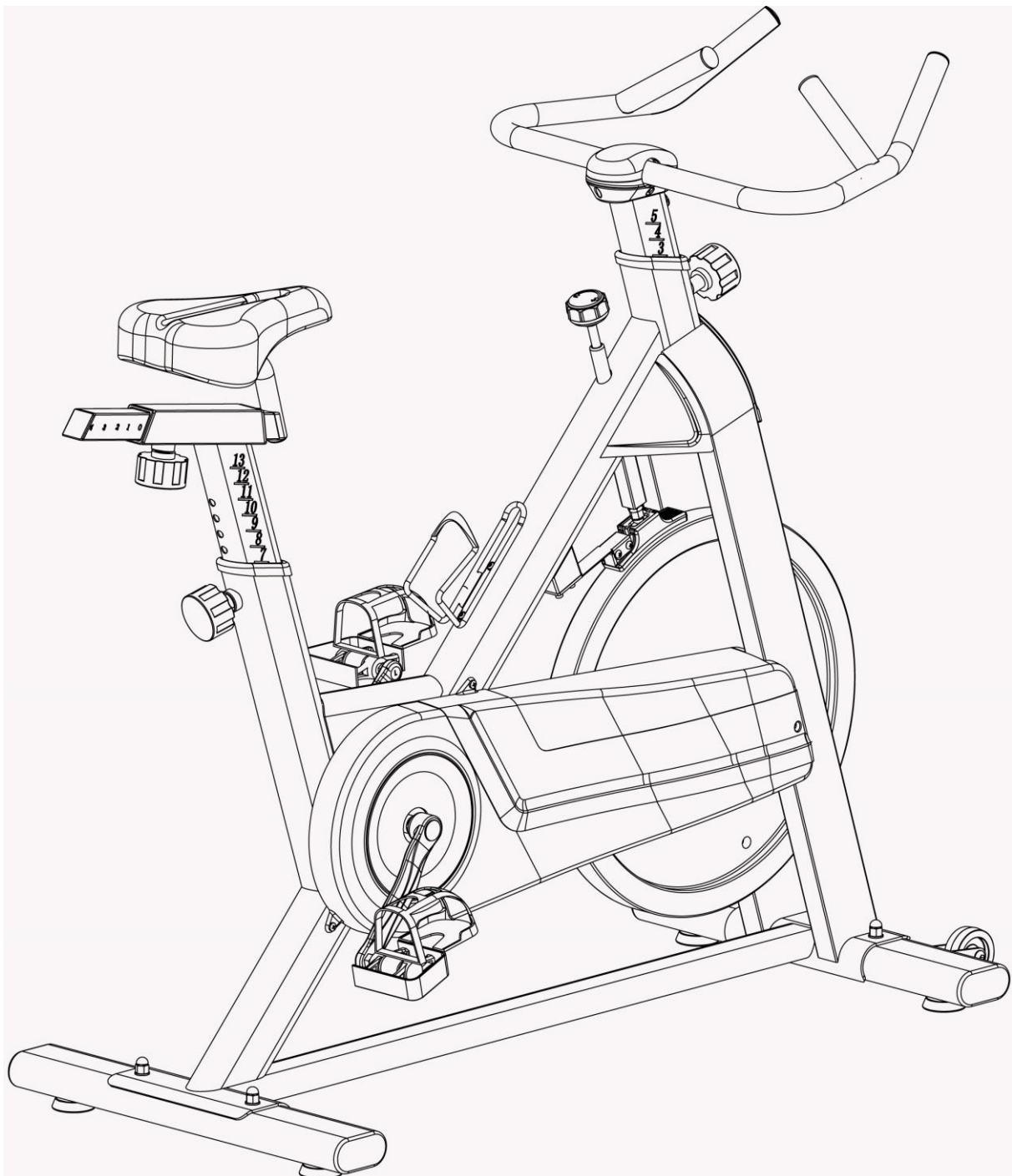

USER MANUAL – EN
IN 9361 Spinning Bike inSPORTline Baraton



CONTENTS

IMPORTANT SAFETY INFORMATION..... 3
EXPLODED VIEW (A)..... 4
EXPLODED VIEW (B)..... 5
PARTS LIST..... 6
ASSEMBLING INSTRUCTIONS 8
TERMS AND CONDITIONS OF WARRANTY, WARRANTY CLAIMS 10

IMPORTANT SAFETY INFORMATION

Please keep this manual in a safe place for reference.

1. It is important to read this entire manual before assembling and using the equipment. Safe and efficient use can only be achieved if the equipment is assembled, maintained and used properly. It is your responsibility to ensure that all users of the equipment are informed of all warnings and precautions.
2. Before starting any exercise program you should consult your doctor to determine if you have any physical or health conditions that could create a risk to your health and safety, or prevent you from using the equipment properly. Your doctor's advice is essential if you are taking medication that affects your heart rate, blood pressure or cholesterol level.
3. Be aware of your body's signals. Incorrect or excessive exercise can damage your health. Stop exercising if you experience any of the following symptoms: Pain, tightness in your chest, irregular heartbeat, extreme shortness of breath, feeling light headed, dizzy or nauseous. If you do experience any of these conditions you should consult your doctor before continuing with your exercise program.
4. Keep children and pets away from the equipment. The equipment is designed for adult use only.
5. Use the equipment on a solid, flat level surface with a protective cover for your floor or carpet. For safety space, the equipment should have at least 0.6 meter of free space all around it.
6. Before using the equipment, check the handlebar, seat, pedals, and the nuts and bolts are securely tightened.
7. The safety level of the equipment can only be maintained if it is regularly examined for damage and/or wear and tear. (E.g. handle bar, pedals, and seat.....)
8. Always use the equipment as indicated. If you find any defective components while assembling or checking the equipment, or if you hear any unusual noises coming from the equipment during use, stop immediately. Do not use the equipment until the problem has been rectified.
9. Wear suitable clothing while using the equipment. Avoid wearing loose clothing that may get caught in the equipment or that may restrict or prevent movement.
10. The equipment has been tested and certified to EN957 under class HC, suitable for domestic, home use only. Maximum weight of user: 120kg. Braking is speed independent.
11. The equipment is not suitable for therapeutic use.
12. Care must be taken when lifting or moving the equipment so as not to injure your back. Always use proper lifting techniques and/or seek assistance if necessary.
13. All moveable accessories (e.g. pedal, handlebar, saddle....etc.) require weekly maintenance. Check them before use every time. If anything broken or loose, please fix them immediately. You may continue using bike after they return to good conditions.

EXPLODED VIEW (A)

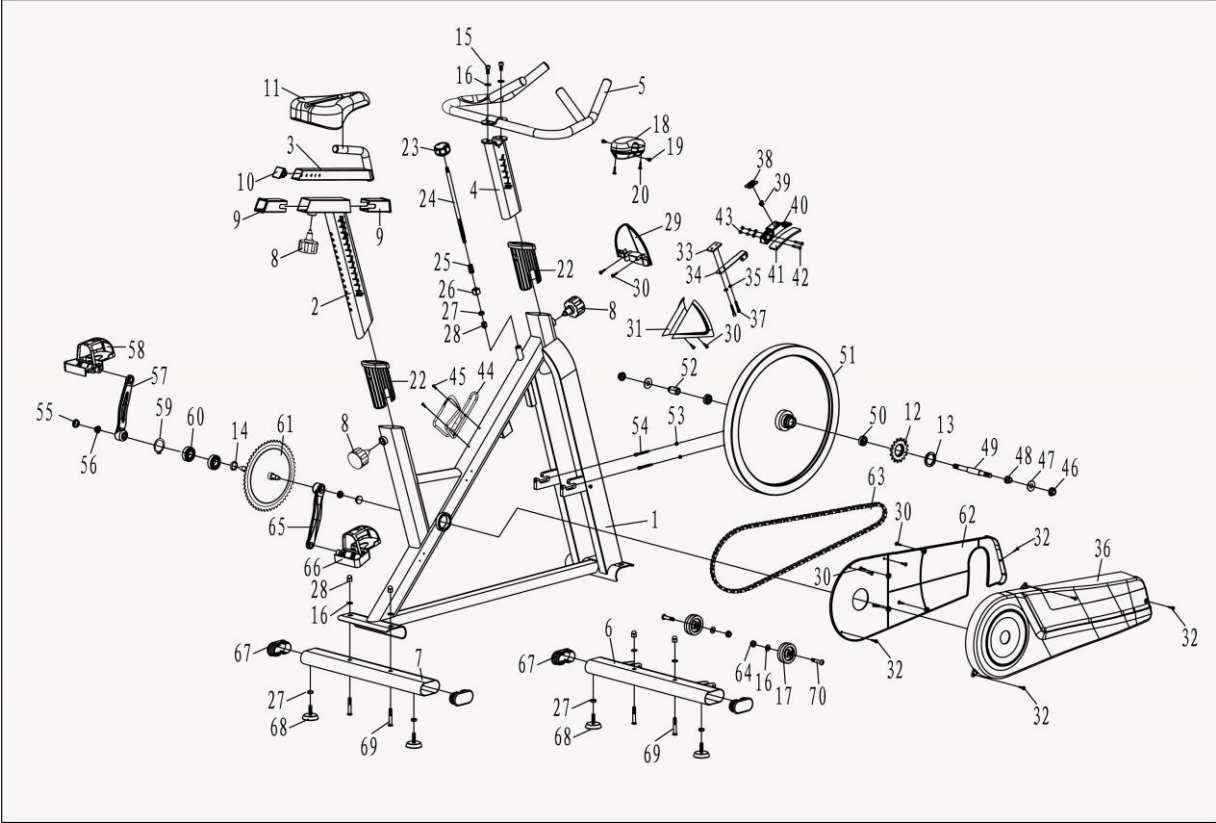

PARTS LIST

NO.	NAME	SPECIFICATION	QTY
1	Main frame		1
2	Seat post	30*70*1.5T*438L	1
3	Seat sliding post	■30*30*2.0T*320L	1
4	Handlebar post	30*70*1.5T*260L	1
5	Handlebar	●φ25*2T	1
6	Front stabilizer	40*80*1.5T*500L	1
7	Rear stabilizer	40*80*1.5T*500L	1
8	Adjusting knob	M16*1.5	3
9	Sleeve	Suit 38*38*1.5T* INNER 30*30	2
10	Bushing	Suit 30*30*1.5T tube	1
11	Saddle		1
12	Small sprocket wheel	φ65.13*16 gear	1
13	Locking ring	φ42*5.0	1
14	Axis spacer	φ26*φ20.2*6T	1
15	Bolt	M8*16L	2
16	Washer	Φ8	8
17	Transportation wheel		2
18	Handlebar decorating cover		1
19	Screw	M4*10L	2
20	Screw	M3*16L	2
21	Wire protector	Φ13	1
22	Sleeve	Outer 40*80*1.5T* inner30*70	2
23	Braking knob	M8	1
24	Braking rod	M10*P1.5*265L	1
25	Compression spring	φ12.4*φ1.4*27L	1
26	M10 compression nut	M10*P1.5*16*16*15L	1
27	Nut	M8	5
28	Domed nut	M8	5
29	Front decorating cover	ABS	1
30	Screw	ST4.2*16	8
31	Frame decoration cover	ABS	1
32	Screw	ST4.2*16 headφ8	7
33	Rob pad	44*25*3	1
34	Spring steel	1.2	1

35	Flat washer		2
36	Outer cover		1
37	Bolt	M5*15	2
38	Brake blockbuster	34.5*23.5*2.0	1
39	Brake spacer	34*24*3	3
40	Brake bracket	ABS	1
41	Felt wool	108*28*6	1
42	Screw	M5*30	2
43	Nylon nut	M5	2
44	Bottle holder		1
45	Screw	M5*15L	2
46	Nut	M12*P1.25	2
47	Washer	φ35*φ12.5*2.0	2
48	Short step tube	φ20*φ12.2*22L	1
49	Flywheel axis	φ15*146*M12*P1.25	1
50	Bearing	6001RS	2
51	Flywheel	φ450*35W	1
52	Long step tube	φ20*φ12.2*25L	1
53	Nut	M6	2
54	Bolt	M6*50	2
55	Crank cover		2
56	Flange nut	M10*P1.25*8T	2
57	Left crank	165L	1
58	Left pedal		1
59	Circlip	φ20	1
60	Bearing	6004	2
61	Sprocket wheel with Axis	52T	1
62	Inner cover		1
63	Chain	d=7.11 p=12.7 112PCS	1
64	Nylon nut	M8	2
65	Right crank	165L	1
66	Right pedal		1
67	Tube plug	OVAL 40*80*1.5T	4
68	Adjusting pad	M8	4
69	Bolt	M8*52 S=20	4
70	Bolt	M8*42L S=20	2

TOOLS

SPANNER:

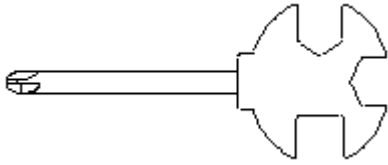

ASSEMBLING INSTRUCTIONS

STEP 1:

Attach the rear stabilizer (pt. 7) to the main frame (pt. 1) using two sets of domed nuts (pt. 28), washers (pt. 16) and bolts (pt. 69) and tighten.

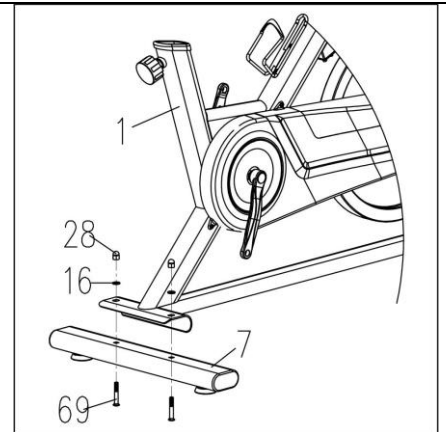

STEP 2:

Attach the front stabilizer (pt. 6) to the main frame (pt. 1) using two sets of domed nuts (pt. 28), washers (pt. 16) and bolts (pt. 69) and tighten.

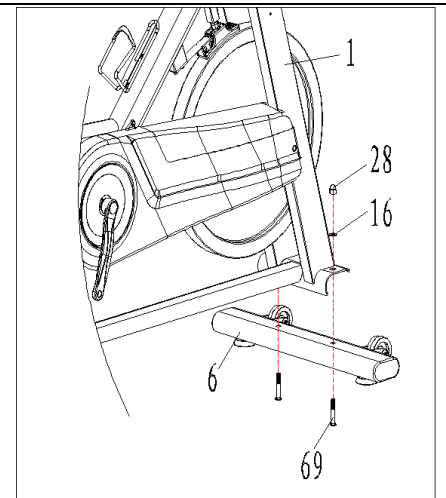

STEP 3:

The pedals (pt. 58, 66) are marked "L" and "R" – Left and Right. Connect them to their appropriate crank arms with the spanner tool and tighten. The right crank arm is on the right-hand side of the cycle as you sit on it.

NOTE: The right pedal should be threaded on clockwise and the left pedal anticlockwise.

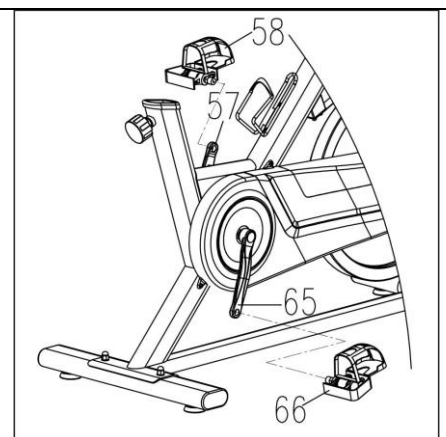

STEP 4:

Slacken the adjusting knob (pt. 8) and pull back and locate the handlebar post (pt. 4) in the housing on the main frame (pt. 1). Align the correct holes at the desired height until the “stop” mark and then tighten the adjusting knob (pt. 8).

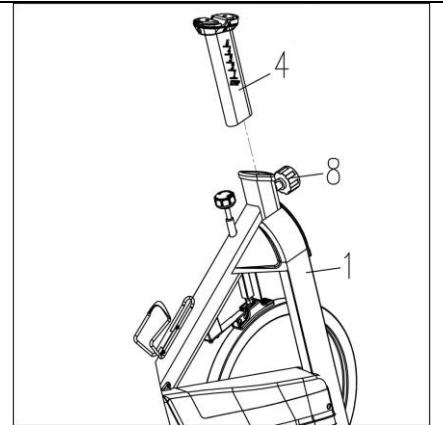
**STEP 5:**

Attach handlebar (pt. 5) to handlebar post (pt. 4) using two sets of washers (pt. 16) and bolts (pt. 15) and tighten.

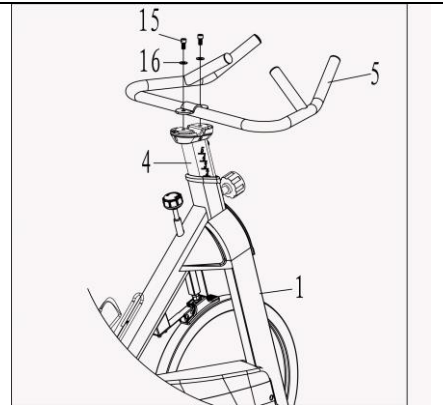
**STEP 6:**

Fix the upper part of handlebar decoration cover (pt. 18) using screws (pt. 20).

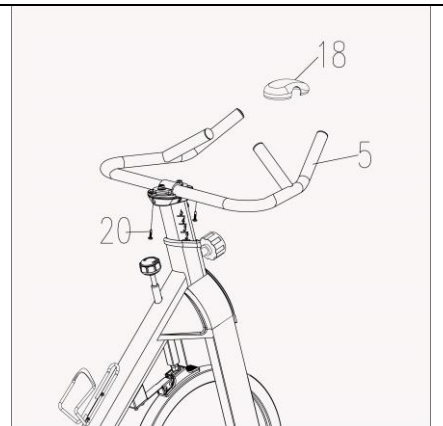
**STEP 7:**

Slacken the knurled section of the round knob (pt. 8) and pull the knob back, slide the seat post (pt. 2) into the seat post housing on the main frame (pt. 1). Then select and align holes for the desired height. Release the knob and retighten the knurled portion.

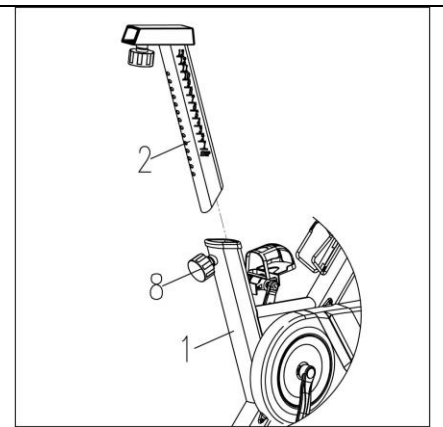

STEP 8:

Fix the seat (pt. 11) to the seat sliding post (pt. 3) as shown, and tighten the bolts around the screws under the seat. You will have to loosen the knurled section of the adjustment knob (pt. 8) and pull the knob back before sliding the sliding seat post (pt. 3) into the seat post (pt. 2) and then select and align holes for the desired distance and tighten the knob.

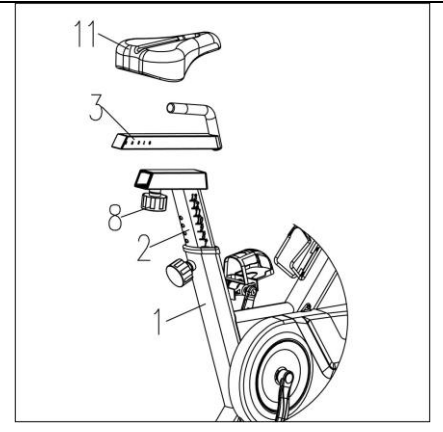

TERMS AND CONDITIONS OF WARRANTY, WARRANTY CLAIMS

General Conditions of Warranty and Definition of Terms

All Warranty Conditions stated hereunder determine Warranty Coverage and Warranty Claim Procedure. Conditions of Warranty and Warranty Claims are governed by Act No. 40/1964 Coll. Civil Code, Act No. 513/1991 Coll., Commercial Code, and Act No. 634/1992 Coll., Consumer Protection Act, as amended, also in cases that are not specified by these Warranty rules.

The seller is SEVEN SPORT s.r.o. with its registered office in Borivojova Street 35/878, Prague 13000, Company Registration Number: 26847264, registered in the Trade Register at Regional Court in Prague, Section C, Insert No. 116888.

According to valid legal regulations it depends whether the Buyer is the End Customer or not.

“The Buyer who is the End Customer” or simply the “End Customer” is the legal entity that does not conclude and execute the Contract in order to run or promote his own trade or business activities.

“The Buyer who is not the End Customer” is a Businessman that buys Goods or uses services for the purpose of using the Goods or services for his own business activities. The Buyer conforms to the General Purchase Agreement and business conditions to the extent specified in the Commercial Code.

These Conditions of Warranty and Warranty Claims are an integral part of every Purchase Agreement made between the Seller and the Buyer. All Warranty Conditions are valid and binding, unless otherwise specified in the Purchase Agreement, in the Amendment to this Contract or in another written agreement.

Warranty Conditions

Warranty Period

The Seller provides the Buyer a 24 months Warranty for Goods Quality, unless otherwise specified in the Certificate of Warranty, Invoice, Bill of Delivery or other documents related to the Goods. The legal warranty period provided to the Consumer is not affected.

By the Warranty for Goods Quality, the Seller guarantees that the delivered Goods shall be, for a certain period of time, suitable for regular or contracted use, and that the Goods shall maintain its regular or contracted features.

The Warranty does not cover defects resulting from:

User's fault, i.e. product damage caused by unqualified repair work, improper assembly, insufficient insertion of seat post into frame, insufficient tightening of pedals and cranks

Improper maintenance

Mechanical damages

Regular use (e.g. wearing out of rubber and plastic parts, joints etc.)

Unavoidable event, natural disaster

Adjustments made by unqualified person

Improper maintenance, improper placement, damages caused by low or high temperature, water, inappropriate pressure, shocks, intentional changes in design or construction etc.

Warranty Claim Procedure

The Buyer is obliged to check the Goods delivered by the Seller immediately after taking the responsibility for the Goods and its damages, i.e. immediately after its delivery. The Buyer must check the Goods so that he discovers all the defects that can be discovered by such check.

When making a Warranty Claim the Buyer is obliged, on request of the Seller, to prove the purchase and validity of the claim by the Invoice or Bill of Delivery that includes the product's serial number, or eventually by the documents without the serial number. If the Buyer does not prove the validity of the Warranty Claim by these documents, the Seller has the right to reject the Warranty Claim.

If the Buyer gives notice of a defect that is not covered by the Warranty (e.g. in the case that the Warranty Conditions were not fulfilled or in the case of reporting the defect by mistake etc.), the Seller is eligible to require a compensation for all the costs arising from the repair. The cost shall be calculated according to the valid price list of services and transport costs.

If the Seller finds out (by testing) that the product is not damaged, the Warranty Claim is not accepted. The Seller reserves the right to claim a compensation for costs arising from the false Warranty Claim.

In case the Buyer makes a claim about the Goods that is legally covered by the Warranty provided by the Seller, the Seller shall fix the reported defects by means of repair or by the exchange of the damaged part or product for a new one. Based on the agreement of the Buyer, the Seller has the right to exchange the defected Goods for a fully compatible Goods of the same or better technical characteristics. The Seller is entitled to choose the form of the Warranty Claim Procedures described in this paragraph.

The Seller shall settle the Warranty Claim within 30 days after the delivery of the defective Goods, unless a longer period has been agreed upon. The day when the repaired or exchanged Goods is handed over to the Buyer is considered to be the day of the Warranty Claim settlement. When the Seller is not able to settle the Warranty Claim within the agreed period due to the specific nature of the Goods defect, he and the Buyer shall make an agreement about an alternative solution. In case such agreement is not made, the Seller is obliged to provide the Buyer with a financial compensation in the form of a refund.

**SEVEN SPORT s.r.o.**

Sídlo: Bořivojova 35/878, 130 00, Praha 3, ČR
Centrála: Dělnická 957, 749 01 Vítkov
Reklamace a servis: Čermenská 486, 749 01 Vítkov

IČO: 26847264
DIČ: CZ26847264
Telefon: +420 556 300 970
Mail: eshop@insportline.cz
reklamace@insportline.cz
servis@insportline.cz
Web: www.insportline.cz

SK**inSPORTline s.r.o.**

Centrála, reklamácie, servis: Električná 6471, 911 01 Trenčín, SK

IČO: 36311723
DIČ: SK2020177082
Telefón: +421(0)326 526 701
Mail: objednavky@insportline.sk
reklamacie@insportline.sk
servis@insportline.sk
Web: www.insportline.sk

Date of Sale:

Stamp and Signature of Seller: