



**USER MANUAL – EN**

**IN 22638 Basketball basket inSPORTline Baltimore**



**CONTENTS**

SAFETY INSTRUCTIONS..... 3  
PARTS LIST ..... 4  
ASSEMBLY ..... 5  
ENVIRONMENT PROTECTION ..... 7  
TERMS AND CONDITIONS OF WARRANTY, WARRANTY CLAIMS..... 7

## SAFETY INSTRUCTIONS

Please read the instruction carefully. Remove all parts and hardware from the carton and place them on soft and clean surface. Check that nothing is missing. Please recycle all packaging materials.

- Follow the instructions carefully. Failure to follow these instructions may result in serious injury or damage.
- Owner must ensure that all users know and follow all rules for safe operation.
- Please assemble and maintain the product carefully to ensure safety.
- If you are using ladder during assembling use it with extreme caution.
- Regularly check the base for leaking. Leaks can cause the product to tip over unexpectedly.
- Seat the pole properly. Failure to do so could lead to separation of pole during transport or play.
- Climate, corrosion or misuse could lead to injury or damage of product.
- If you need help contact customer service.
- It is recommended to fill the base with sand and not water. If you fill the base with water, please check for leaking. Leaking can lead to tip over of the product.
- If you fill the base with water, please empty the base or add 7.57 liters of anti-freeze before the temperature reach to or below 0 °C. Freezing water may crack the base.
- Without the base filled with water or sand, you cannot use the product. The product may tip over and injuries or death.
- Store the basket in a horizontal position without the filled base (place it on the ground).
- Place the basket on a firm, level surface.
- Make sure the product is firmly positioned and in a stable position before use.
- The product is not a toy.
- Never use the product near water.
- Wear comfortable sports clothing during use. Always wear sports shoes.
- Do not make unauthorized modifications or modifications.
- Children may only use the product under the supervision of their parents.
- Assembly may only be carried out by an adult. Two adults are required for assembly.
- Check the condition of the product regularly. Stop using the product immediately if it is worn or damaged.
- Use only original spare parts.
- Do not wear jewelry during use.
- Do not climb on the stand.
- Do not hang up on the hoop.
- Never throw or hang on the basket during the smash.
- Consult a physician before starting an exercise session.
- **WARNING:** Overextended during training can cause serious injury or death. If you feel sick, stop exercising immediately!
- Suitable for schools and sports clubs, for indoor and outdoor use

# PARTS LIST

No.	Specifications / Name	Qty.
1	Board	1
2	Rim	1
3	Mesh	1
4	Board Bracket	1
5	Bolt M8x45mm	4
6	Nut	4
7	Bolt M8x16mm	2
8	Bolt M12x90mm	2
9	Nut	2
10	Cap	1
11	Top Pole	1
12	Middle Pole	1
13	Bottom Pole	1
14	Base	1
15	Wheel Shaft	1
16	Wheel	1 set
17	Bolt M10x100mm	1
18	Nut	1
19	Pole Brace	2
20	Bolt M8x20mm	2
21	Nut	2
22	Hand Knob	1
23	Bolt M10x90mm	2
24	Bolt M8x120mm	2
25	Spring Washer	2
26	Spring	2

## ASSEMBLY

### WARNING!

Assembly can only be performed by an adult.

4 adults are recommended for installation.

- Unpack all parts from the box and check that none are missing.
- Attach the rim (2) and the board holder (4) to the board (1) with bolts (5, 24) and nuts (6).
- Then fasten the upper part of the board holder (4) to the board (1) with bolts (7). Attach the top pole (11) to the board holder (4) with bolts (8) and nuts (9). **(The arms of the holder (4) must first be bent by hand - they are delivered in parallel in the package.)**
- Connect the top post (11) to the middle post (12) and then the middle post (12) to the bottom post (13). Connect the posts (11) and (12) with the hand knob (22) and bolts (23). Connect posts (12) and (13) with bolts (23)
- Place the base (14) on a flat surface. Attach the wheels (16) to the base with axle (15) and then the post (13).
- Attach the supports (19) to the bottom post (13) with bolts (17) and nuts (18). Then fasten the supports (19) to the base (14) with bolts (20) and nuts (21).
- Then pour sand or water into the base.

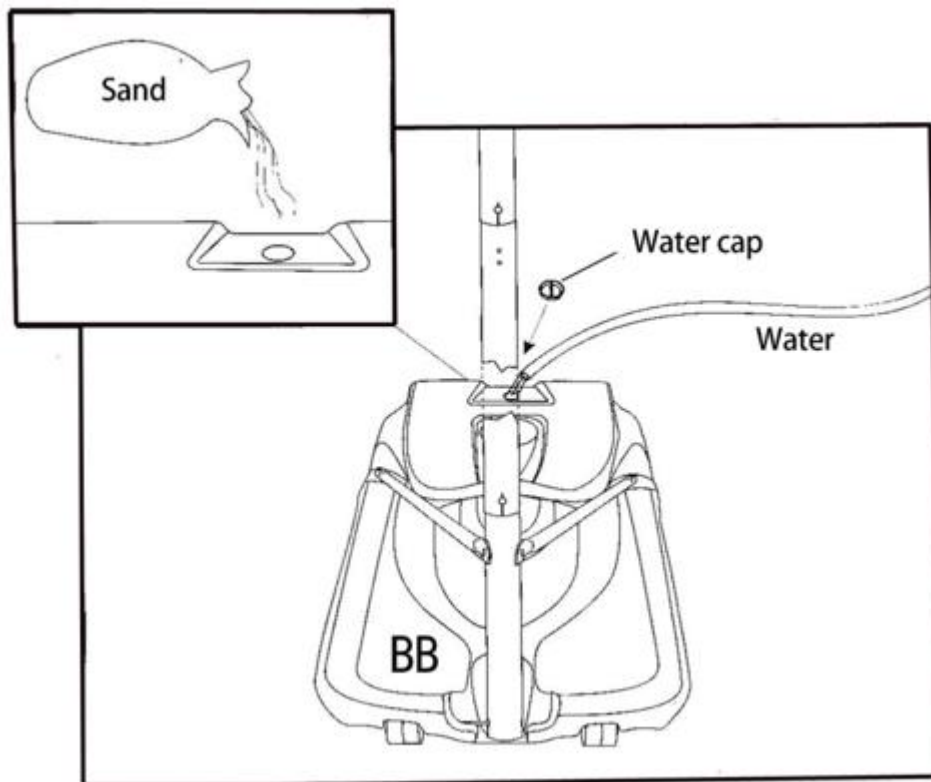

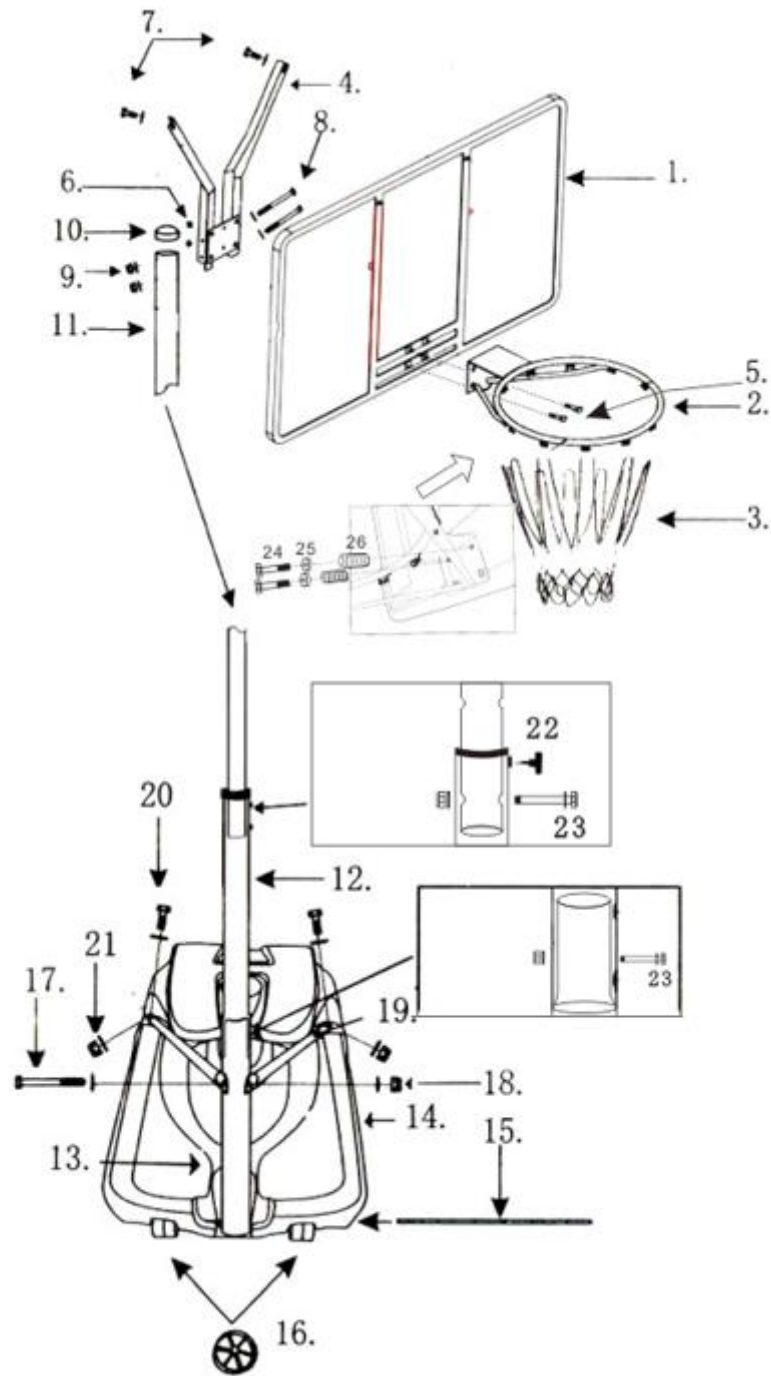

## MOVING

- Before moving, lower the basket to the lowest possible value.
- Pay attention to surface irregularities.
- Then carefully place the basket on a flat surface and slowly adjust the desired height.

## ENVIRONMENT PROTECTION

After the product lifespan expired or if the possible repairing is uneconomic, dispose it according to the local laws and environmentally friendly in the nearest scrapyards.

By proper disposal you will protect the environment and natural sources. Moreover, you can help protect human health. If you are not sure in correct disposing, ask local authorities to avoid law violation or sanctions.

## TERMS AND CONDITIONS OF WARRANTY, WARRANTY CLAIMS

### General Conditions of Warranty and Definition of Terms

All Warranty Conditions stated here under determine Warranty Coverage and Warranty Claim Procedure. Conditions of Warranty and Warranty Claims are governed by Act No. 89/2012 Coll. Civil Code, and Act No. 634/1992 Coll., Consumer Protection, as amended, also in cases that are not specified by these Warranty rules.

The seller is SEVEN SPORT s.r.o. with its registered office in Strakonická street 1151/2c, Prague 150 00, Company Registration Number: 26847264, registered in the Trade Register at Regional Court in Prague, Section C, Insert No. 116888.

According to valid legal regulations it depends whether the Buyer is the End Customer or not.

“The Buyer who is the End Customer” or simply the “End Customer” is the legal entity that does not conclude and execute the Contract in order to run or promote his own trade or business activities.

“The Buyer who is not the End Customer” is a Businessman that buys Goods or uses services for the purpose of using the Goods or services for his own business activities. The Buyer conforms to the General Purchase Agreement and business conditions.

These Conditions of Warranty and Warranty Claims are an integral part of every Purchase Agreement made between the Seller and the Buyer. All Warranty Conditions are valid and binding, unless otherwise specified in the Purchase Agreement, in the Amendment to this Contract or in another written agreement.

### Warranty Conditions

#### Warranty Period

The Seller provides the Buyer a 24 months Warranty for Goods Quality, unless otherwise specified in the Certificate of Warranty, Invoice, Bill of Delivery or other documents related to the Goods. The legal warranty period provided to the Consumer is not affected.

By the Warranty for Goods Quality, the Seller guarantees that the delivered Goods shall be, for a certain period of time, suitable for regular or contracted use, and that the Goods shall maintain its regular or contracted features.

#### The Warranty does not cover defects resulting from (if applicable):

- User's fault, i.e. product damage caused by unqualified repair work, improper assembly, insufficient insertion of seat post into frame, insufficient tightening of pedals and cranks
- Improper maintenance
- Mechanical damages
- Regular use (e.g. wearing out of rubber and plastic parts, moving mechanisms, joints, wear of brake pads/blocks, chain, tires, cassette/multi wheel etc.)
- Unavoidable event, natural disaster
- Adjustments made by unqualified person
- Improper maintenance, improper placement, damages caused by low or high temperature, water, inappropriate pressure, shocks, intentional changes in design or construction etc.

### Warranty Claim Procedure

The Buyer is obliged to check the Goods delivered by the Seller immediately after taking the responsibility for the Goods and its damages, i.e. immediately after its delivery. The Buyer must check the Goods so that he discovers all the defects that can be discovered by such check.

When making a Warranty Claim the Buyer is obliged, on request of the Seller, to prove the purchase and validity of the claim by the Invoice or Bill of Delivery that includes the product's serial number, or eventually by the documents without the serial number. If the Buyer does not prove the validity of the Warranty Claim by these documents, the Seller has the right to reject the Warranty Claim.

If the Buyer gives notice of a defect that is not covered by the Warranty (e.g. in the case that the Warranty Conditions were not fulfilled or in the case of reporting the defect by mistake etc.), the Seller is eligible to require a compensation for all the costs arising from the repair. The cost shall be calculated according to the valid price list of services and transport costs.

If the Seller finds out (by testing) that the product is not damaged, the Warranty Claim is not accepted. The Seller reserves the right to claim a compensation for costs arising from the false Warranty Claim.

In case the Buyer makes a claim about the Goods that is legally covered by the Warranty provided by the Seller, the Seller shall fix the reported defects by means of repair or by the exchange of the damaged part or product for a new one. Based on the agreement of the Buyer, the Seller has the right to exchange the defected Goods for a fully compatible Goods of the same or better technical characteristics. The Seller is entitled to choose the form of the Warranty Claim Procedures described in this paragraph.

The Seller shall settle the Warranty Claim within 30 days after the delivery of the defective Goods, unless a longer period has been agreed upon. The day when the repaired or exchanged Goods is handed over to the Buyer is considered to be the day of the Warranty Claim settlement. When the Seller is not able to settle the Warranty Claim within the agreed period due to the specific nature of the Goods defect, he and the Buyer shall make an agreement about an alternative solution. In case such agreement is not made, the Seller is obliged to provide the Buyer with a financial compensation in the form of a refund.

**CZ**  
**SEVEN SPORT s.r.o.**

Registered Office: Strakonická 1151/2c, Praha 5, 150 00, ČR  
Headquarters: Dělnická 957, Vítkov, 749 01  
Warranty & Service: Čermenská 486, Vítkov 749 01

CRN: 26847264  
VAT ID: CZ26847264

Phone: +420 556 300 970  
E-mail: eshop@insportline.cz  
reklamace@insportline.cz  
servis@insportline.cz

Web: www.inSPORTline.cz

**SK**  
**inSPORTline s.r.o.**

Headquarters, warranty & service center: Električná 6471, Trenčín 911 01, SK

CRN: 36311723  
VAT ID: SK2020177082

Phone: +421(0)326 526 701  
E-mail: objednavky@insportline.sk  
reklamacie@insportline.sk  
servis@insportline.sk

Web: www.inSPORTline.sk