

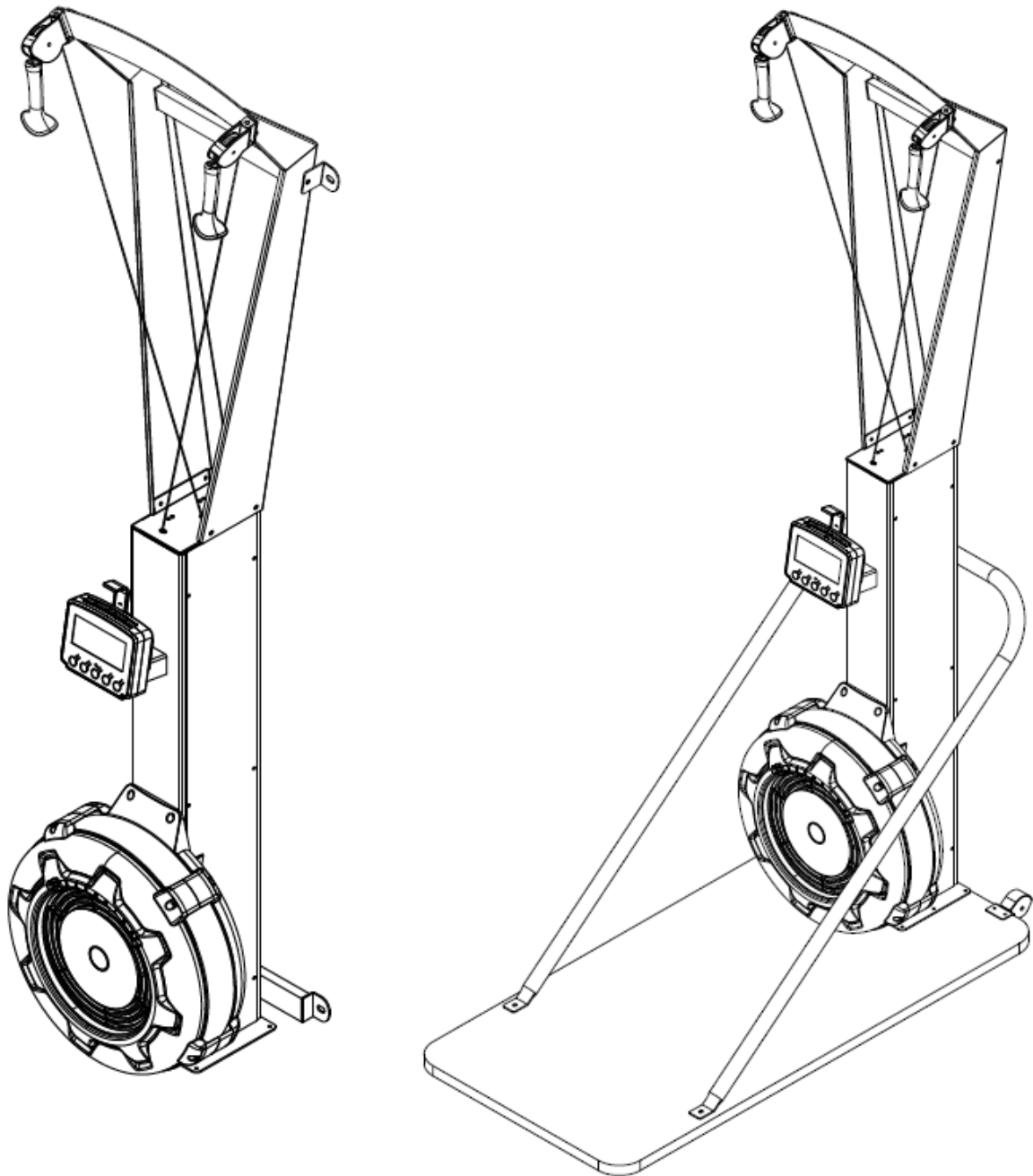

USER MANUAL – EN

IN 19986 Cross-country trainer inSPORTline SKI2000



CONTENTS

- SAFETY INSTRUCTIONS..... 3
- CROSS-COUNTRY TRAINER – FREE STANDING..... 3
- PRODUCT DESCRIPTION 3
- ASSEMBLY 4
- CROSS-COUNTRY TRAINER – WALL MOUNTING 13
- PRODUCT DESCRIPTION 13
- ASSEMBLY 13
- CONSOLE 22
 - BUTTONS 22
 - DISPLAY 23
 - PROGRAMS 24
- USE 25
 - USE AND TRAINING 25
 - IMPORTANT SAFETY INSTRUCTIONS..... 25
 - DOUBLE-POLE TECHNIQUE 26
 - CLASSIC CROSS-COUNTRY TECHNIQUE (ARM CENTER) 27
- STORAGE 28
- DIAGRAM – FREE STANDING..... 29
- PARTS LIST – FREE STANDING..... 30
- DIAGRAM – WALL MOUNTED 32
- PARTS LIST – WALL ASSEMBLY..... 33
- ENVIRONMENT PROTECTION 34
- TERMS AND CONDITIONS OF WARRANTY, WARRANTY CLAIMS..... 34

SAFETY INSTRUCTIONS

- Read the manual carefully and keep it for future reference.
- Keep the distance from another object at least 0,6 m.
- Adjustable parts can not prohibit the movement of the user.
- Do not modify the product.
- Read all warning labels before use.
- Keep away from kids and pets.
- It is recommended to use protection mat.
- Regularly check the parts for damage or wear.
- Regularly check all joints and screws, tighten them regularly.
- Consult a physician before use. If you experience nausea or other health problems during exercise, stop exercising immediately and contact your doctor.
- Wear suitable sports cloths including shoes. Do not wear loose cloths.
- Only for one person at a time.
- Use: SC for commercial and professional use according to EN 957
- **WARNING:** The heart rate monitoring system may not be accurate. Overextending during training can cause serious injury or death. If you feel sick, stop exercising immediately!

CROSS-COUNTRY TRAINER – FREE STANDING

PRODUCT DESCRIPTION

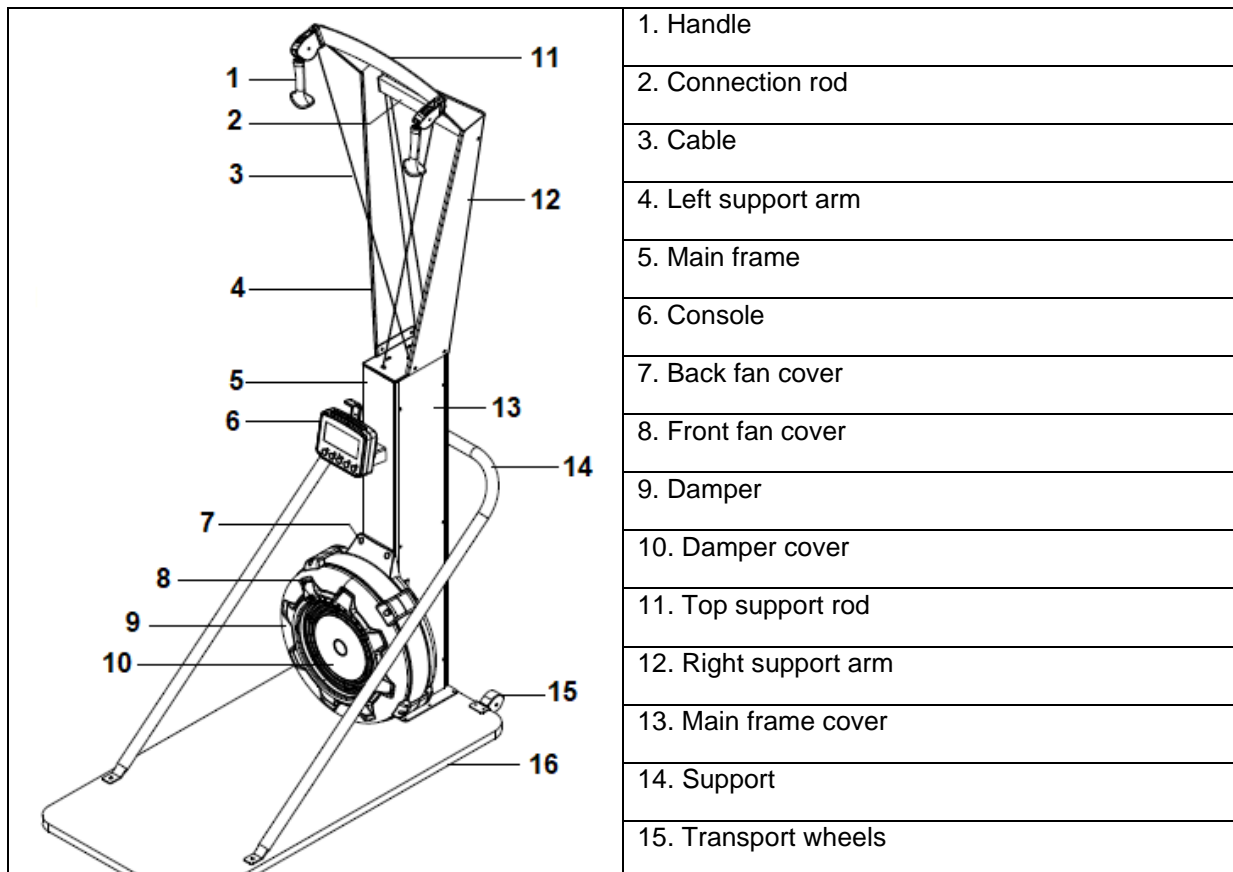



	16. Wooden base
--	-----------------





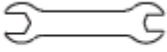

ASSEMBLY



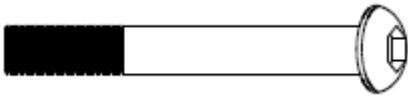

TOOLS

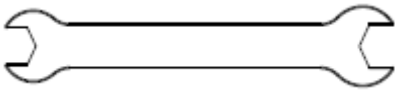
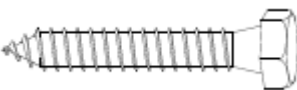
Tools are included.

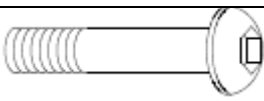
			
Allen key 6 mm	Screwdriver	Allen key 5 mm	Wrench

ASSEMBLY MATERIAL

Picture	No.	Description	Qty.
	82	Allen screw M8x75 mm	1
	71	Flat washer M8	13
	72	Nut M8	1
	86	Screw M8x12 mm	10
	87	Screw M8x15 mm	2
	89	Allen screw 6 mm	1
	88	Wrench	1
Wall mounting			
	54	Screw ST8x50 mm	1
	53	Screw M8x35 mm	2
	71	Flat washer M8	2
	55	Flat washer $\Phi 22 \times \Phi 9 \times 2.0$ mm	4
Free standing			
	84	Screw M8x50 mm	2

	85	Arc washer M8	2
	83	Allen screw M8x30 mm	6
	71	Flat washer M8	6
	90	Allen key 5 mm	1

STEP 1

Remove top frame (4) and main frame (1).

NOTE: Be careful with covers

Do not throw away the packaging material immediately but dispose of it only after finishing the assembly.

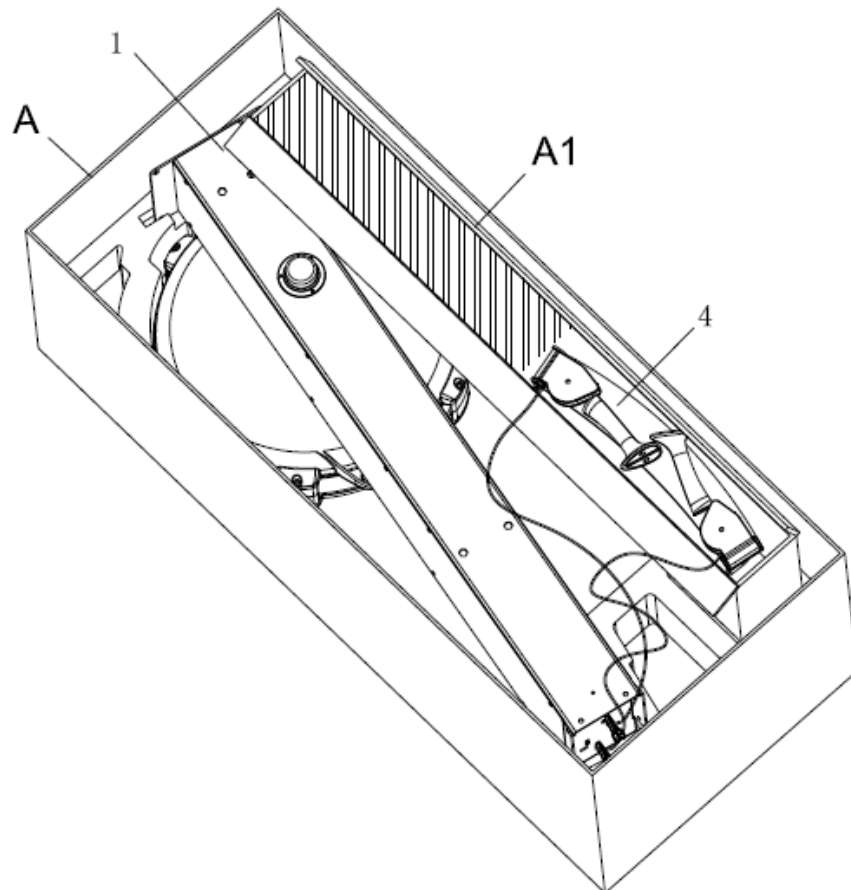





STEP 2

Connect the Left/Right support arm (2/3) to the main frame (1) with 4 screws (86) and washers (71). Tighten them.

STEP 3

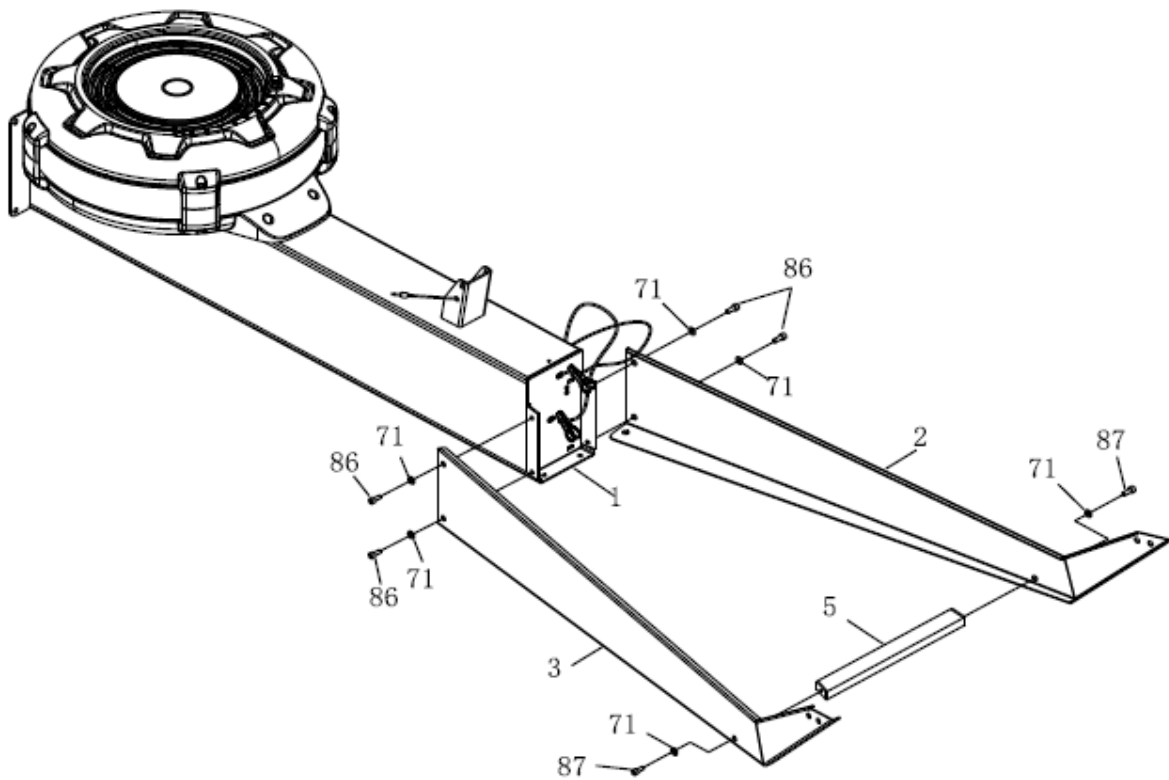

Connect the connection rod (5) to the Left/Right support arm (2/3) with 2 screws (87) and washers (71). Tighten them.

 — #86 M8X12mm 4PCS	#89 Allen Wrench 6mm 
 — #87 M8X15mm 2PCS	
 — #71 M8 6PCS	



STEP 4

Connect top frame (4) to the Left/Right support arm (2/3) with 4 screws (86) and washers (71). Tighten them.

 #86 M8X12mm 4PCS	 #89 Allen Wrench 6mm
 #71 M8 4PCS	

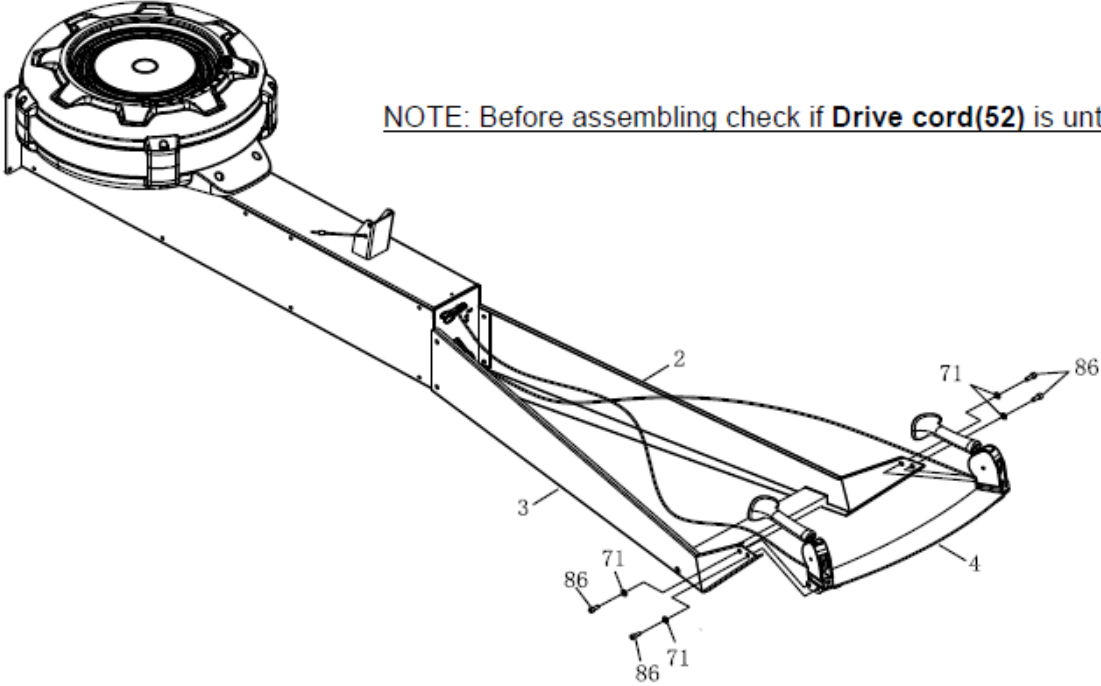

NOTE: Check if the Drive cord (52) is untangled.

STEP 5

Stand up the construction. Tighten Left/Right support arm (2/3) with screws (86) and washer (71). Tighten them.

STEP 6

Remove the clicker from the drive cord (52).

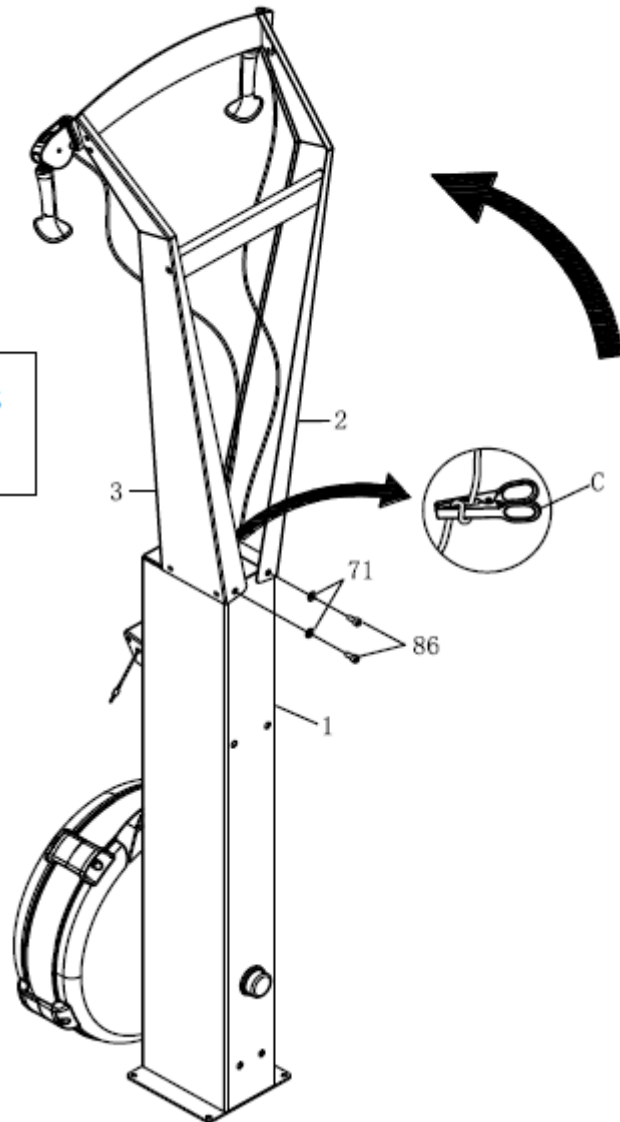
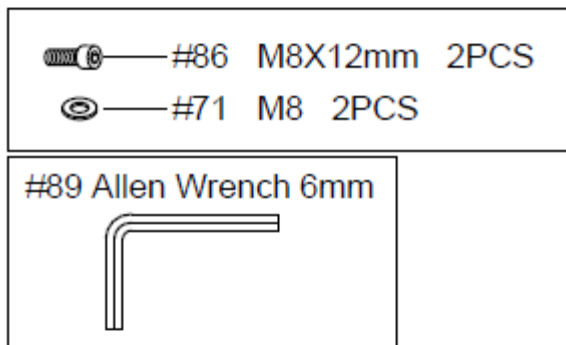

STEP 7

Connect the mobile holder (15) to the console (14) with rubber band (34)

STEP 8

Connect the console (14) to the console holder on the main frame (1) with 1 screw (82), washer (71) a nut (72).

STEP 9

Connect the sensor cable (17) to the console (14a)

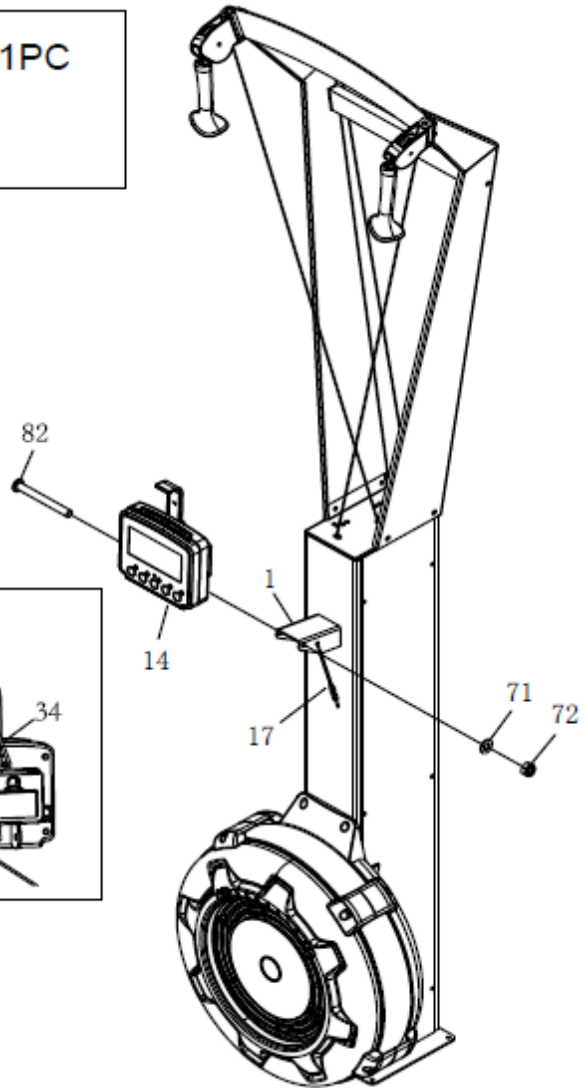
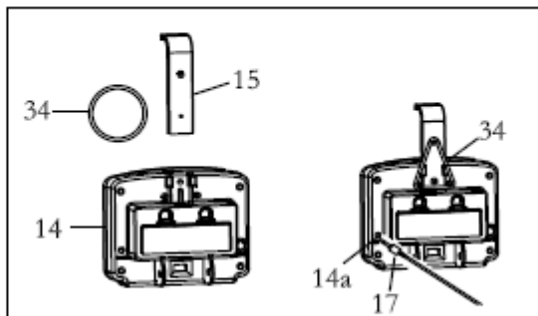
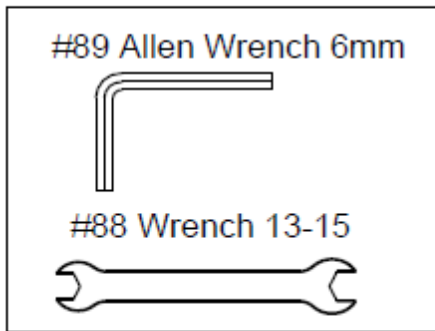
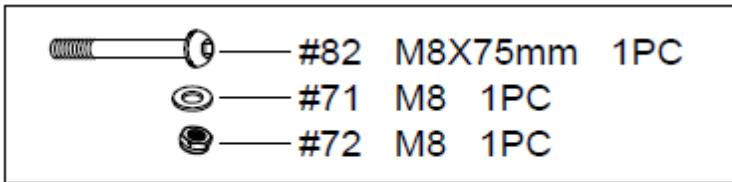

STEP 10

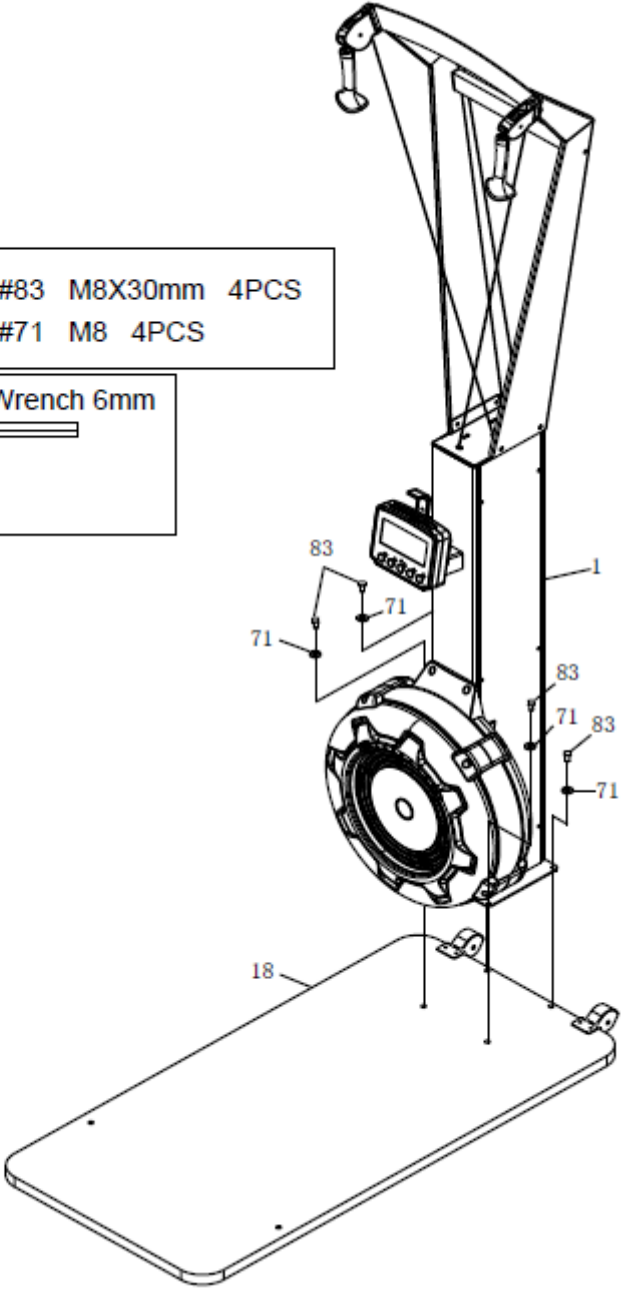
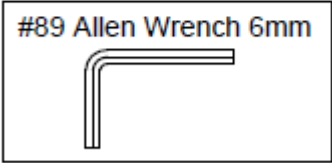

Connect the main frame (1) to the wooden base (18) with 4 screws (83) and flat washers (71)

- #83 M8X30mm 4PCS
- #71 M8 4PCS

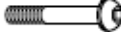

STEP 11

Connect the support rod (14) to the main frame (1) with 2 screws (84), washers (85) and bracket cushion (42).

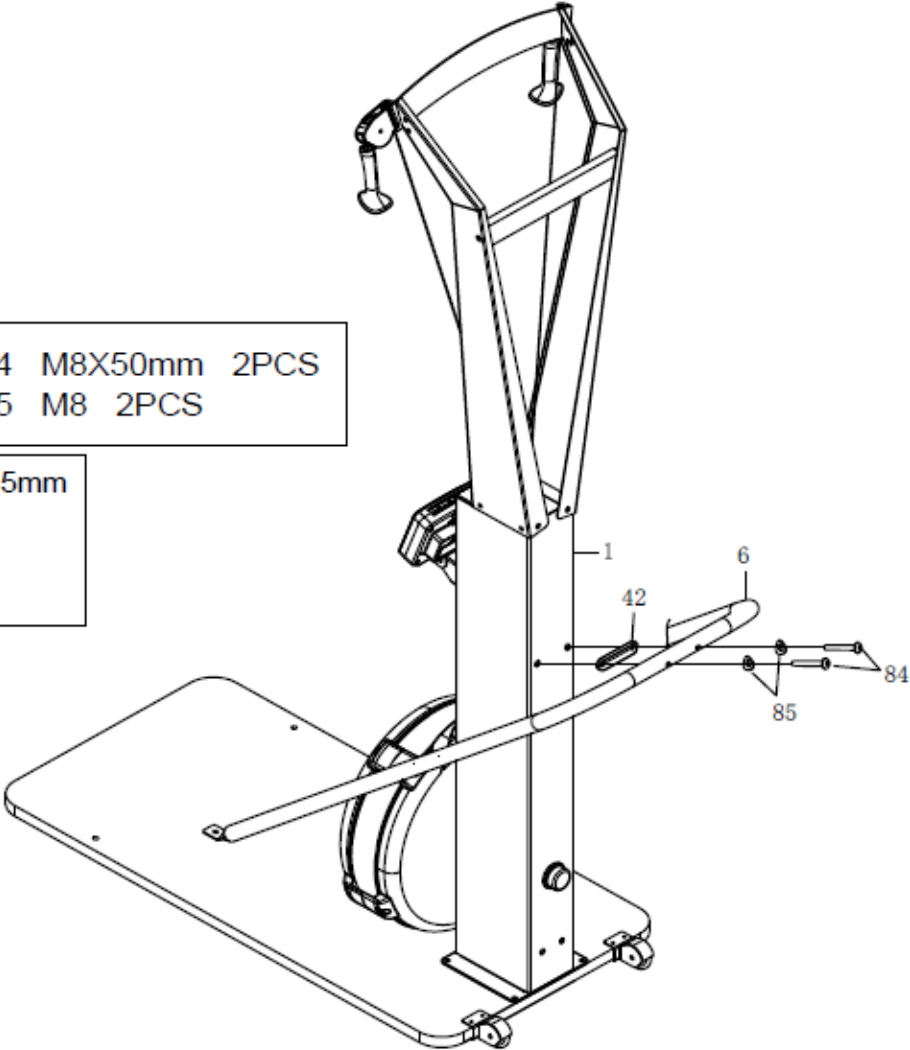
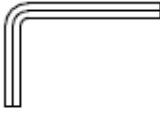

-  #84 M8X50mm 2PCS
-  #85 M8 2PCS

#90 Allen Wrench 5mm



STEP 12

Connect the support rod (6) to the wooden base (18) with 2 screws (83) and washers (71). Tighten them.

 #83 M8X30mm 2PCS
 #71 M8 2PCS

#89 Allen Wrench 6mm

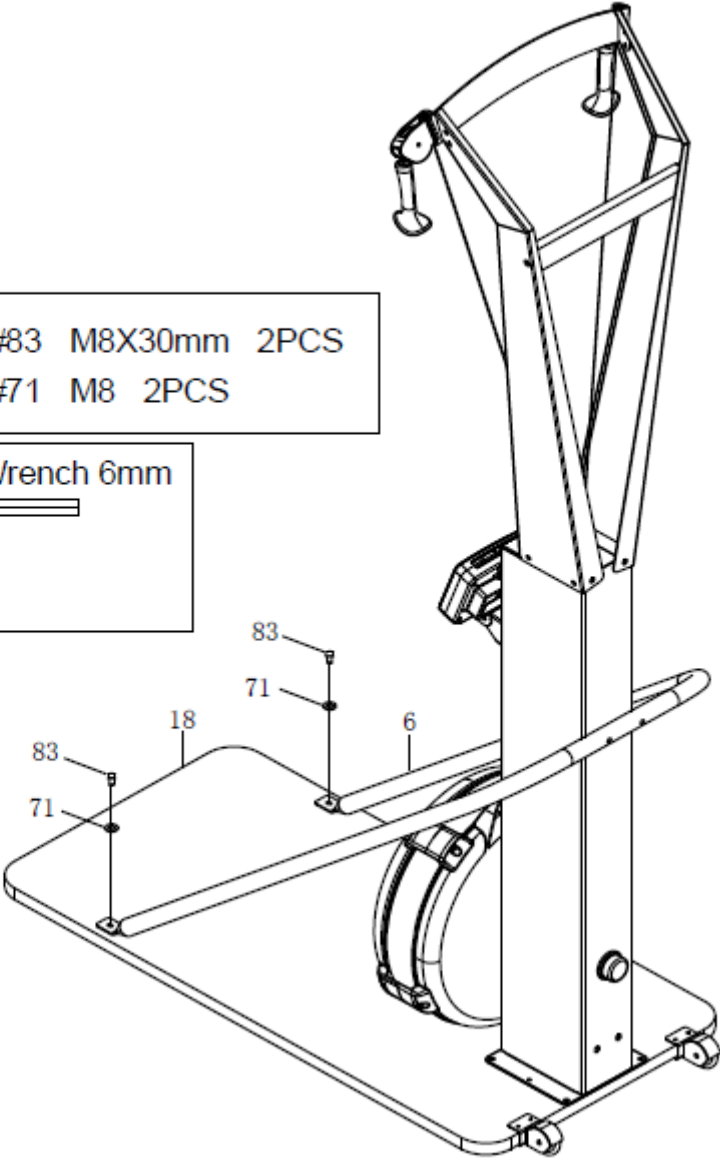

CROSS-COUNTRY TRAINER – WALL MOUNTING

PRODUCT DESCRIPTION

	1. Handle
	2. Connection rod
	3. Cable
	4. Left support arm
	5. Main frame
	6. Console
	7. Back fan cover
	8. Front fan cover
	9. Damper
	10. Damper cover
	11. Top support rod
	12. Wall mounting - top
	13. Right support arm
	14. Support
	15. Wall mounting - bottom

ASSEMBLY





TOOLS

Tools are included.

Allen key 6 mm	Screwdriver	Wrench

ASSEMBLY MATERIAL

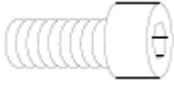
Picture	No.	Description	Qty.
	82	Screw M8x75 mm	1

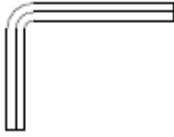
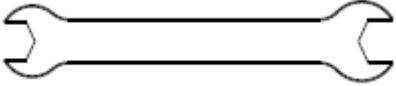
	54	Screw ST8x50 mm	4
	53	Screw M8x35 mm	2
	72	Nut M8	1
	86	Screw M8x12 mm	10
	87	Screw M8x15 mm	2
	71	Flat washer M8	15
	55	Flat washer $\Phi 22 \times \Phi 9 \times 2.0$ mm	4
	89	Allen key 6 mm	1
	88	Wrench 13-15	1

STEP 1

Remove top frame (4) and main frame (1).

NOTE: Be careful with covers

Do not throw away the packaging material immediately but dispose of it only after finishing the assembly.

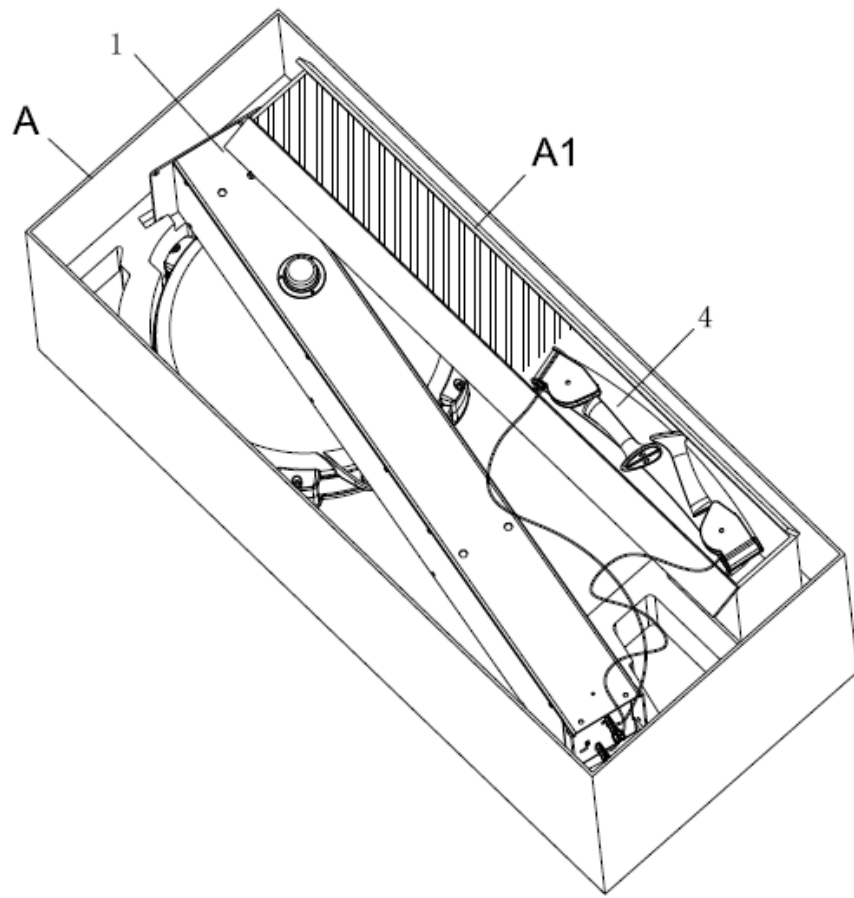





STEP 2

Connect the Left/Right support arm (2/3) to the main frame (1) with 4 screws (86) and washers (71). Tighten them.

STEP 3

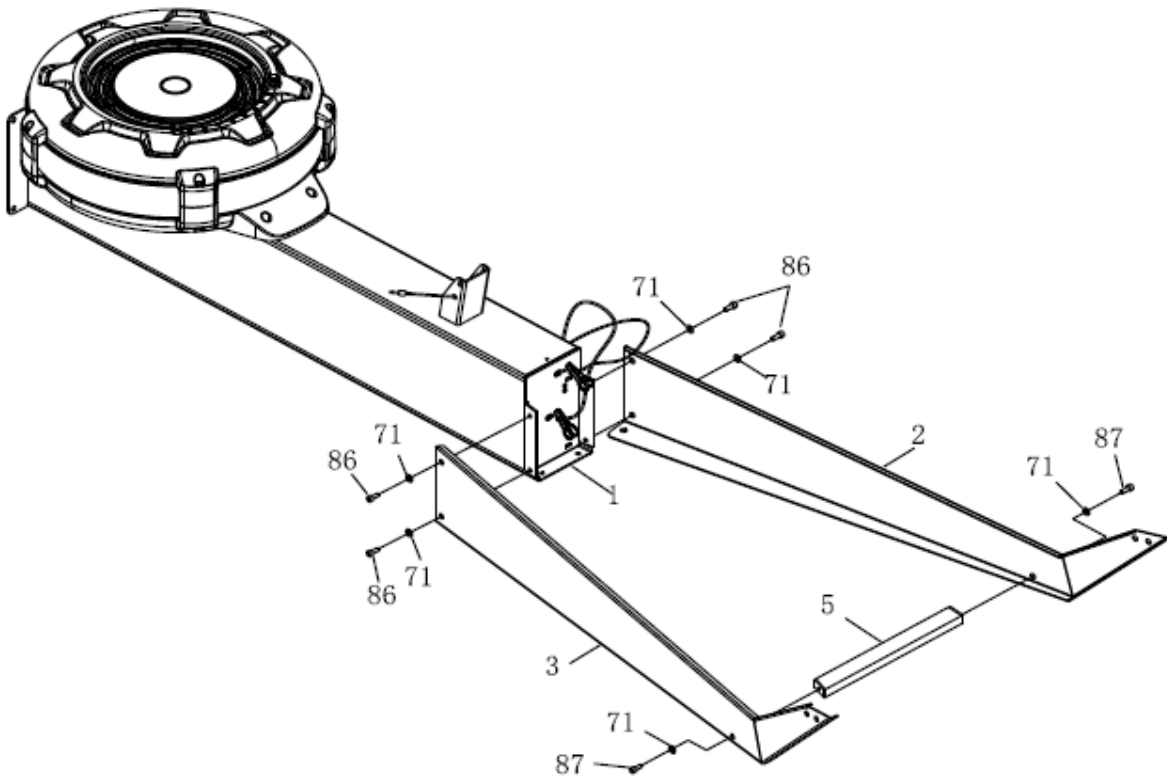

Connect the connection rod (5) to the Left/Right support arm (2/3) with 2 screws (87) and washers (71). Tighten them.

 — #86 M8X12mm 4PCS	#89 Allen Wrench 6mm 
 — #87 M8X15mm 2PCS	
 — #71 M8 6PCS	



STEP 4

Connect top frame (4) to the Left/Right support arm (2/3) with 4 screws (86) and washers (71). Tighten them.

 #86 M8X12mm 4PCS	 #89 Allen Wrench 6mm
 #71 M8 4PCS	

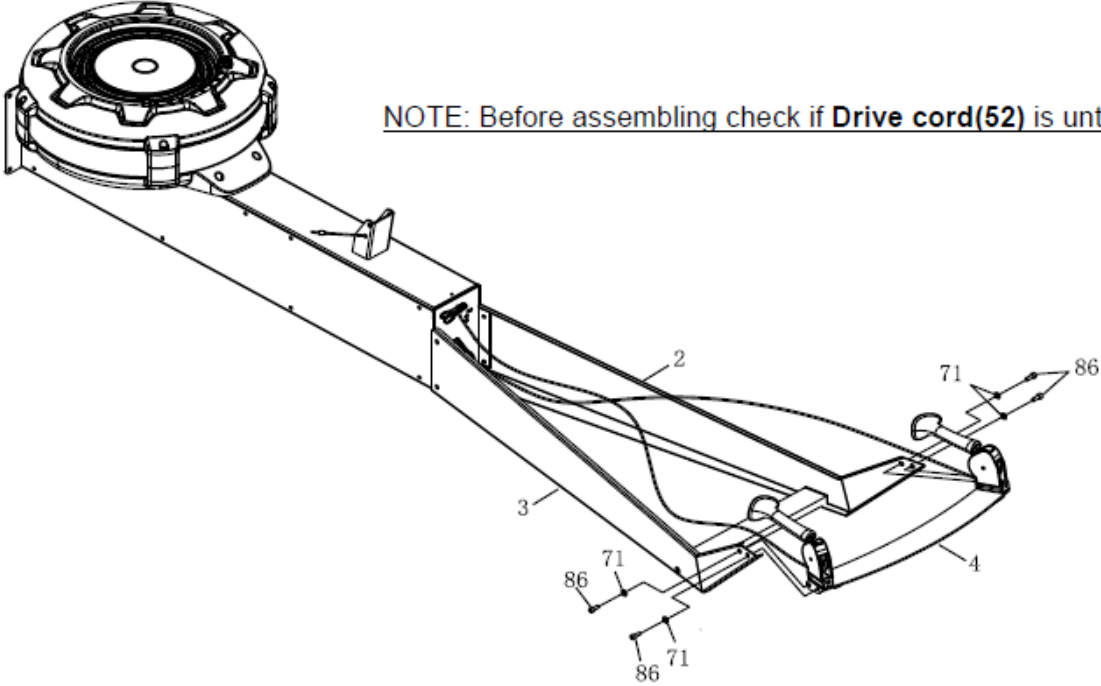

NOTE: Before assembling check if Drive cord(52) is untangled.

NOTE: Check if the Drive cord (52) is untangled.

STEP 5

Stand up the construction. Tighten Left/Right support arm (2/3) with screws (86) and washer (71). Tighten them.

STEP 6

Remove the clicker from the drive cord (52).

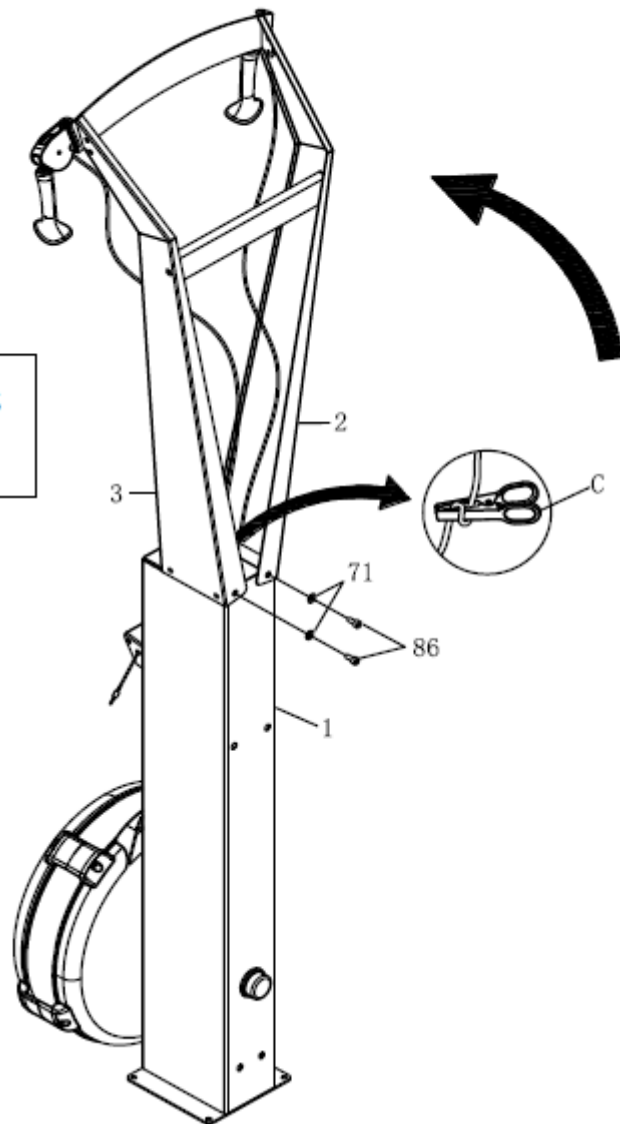
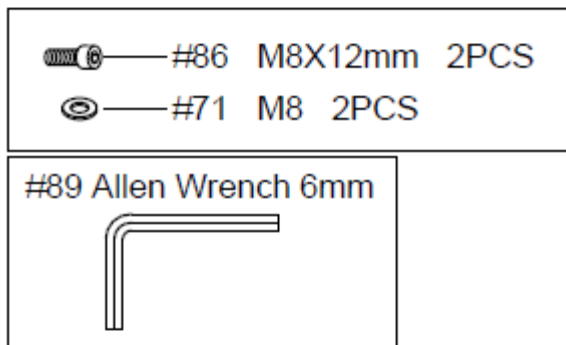

STEP 7

Connect the mobile holder (15) to the console (14) with rubber band (34)

STEP 8

Connect the console (14) to the console holder on the main frame (1) with 1 screw (82), washer (71) a nut (72).

STEP 9

Connect the sensor cable (17) to the console (14a)

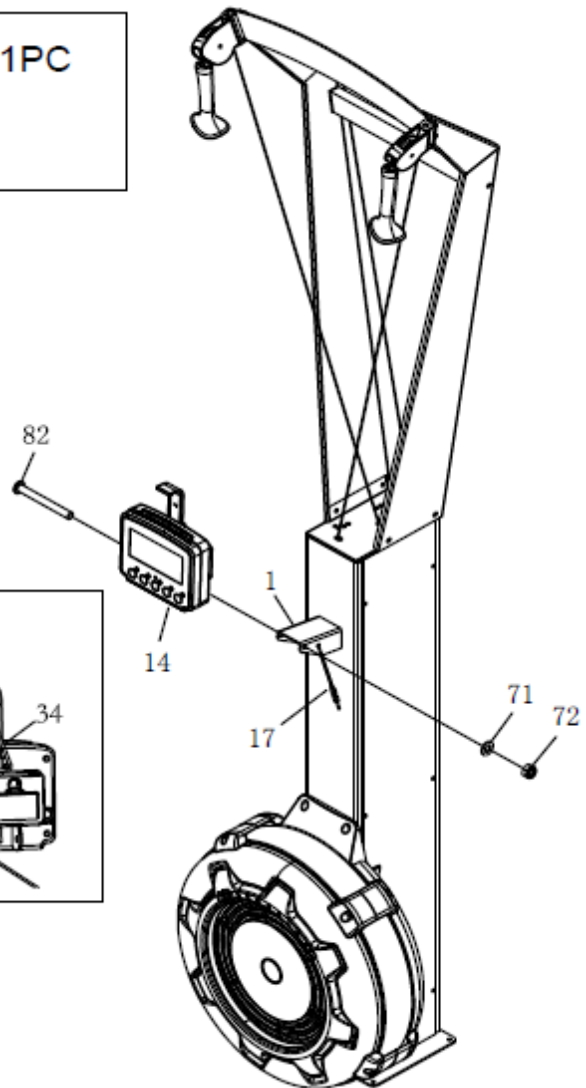
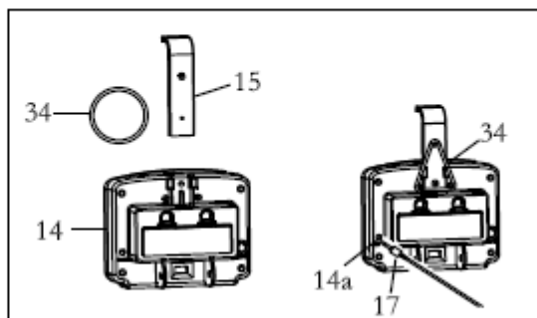
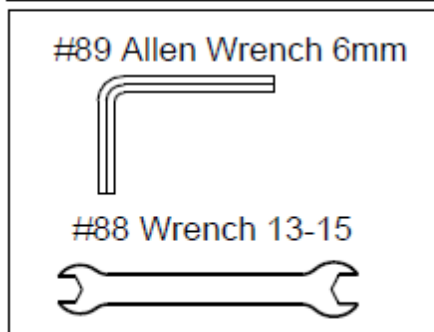
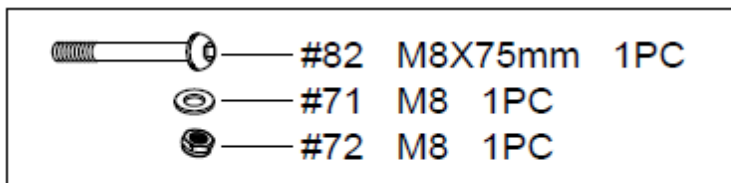

KROK 10

Connect the wall mounting – bottom (8) to the main frame (1) with 2 screws M8x35 mm and flat washer (71).

KROK 11

Remove one screw (87) and washer (71) from left support arm (2). Connect wall mounting - top (9) with the same screw and washer.

KROK 12

Remove one screw (87) and washer (71) from right support arm (2). Connect wall mounting - top (9) with the same screw and washer.

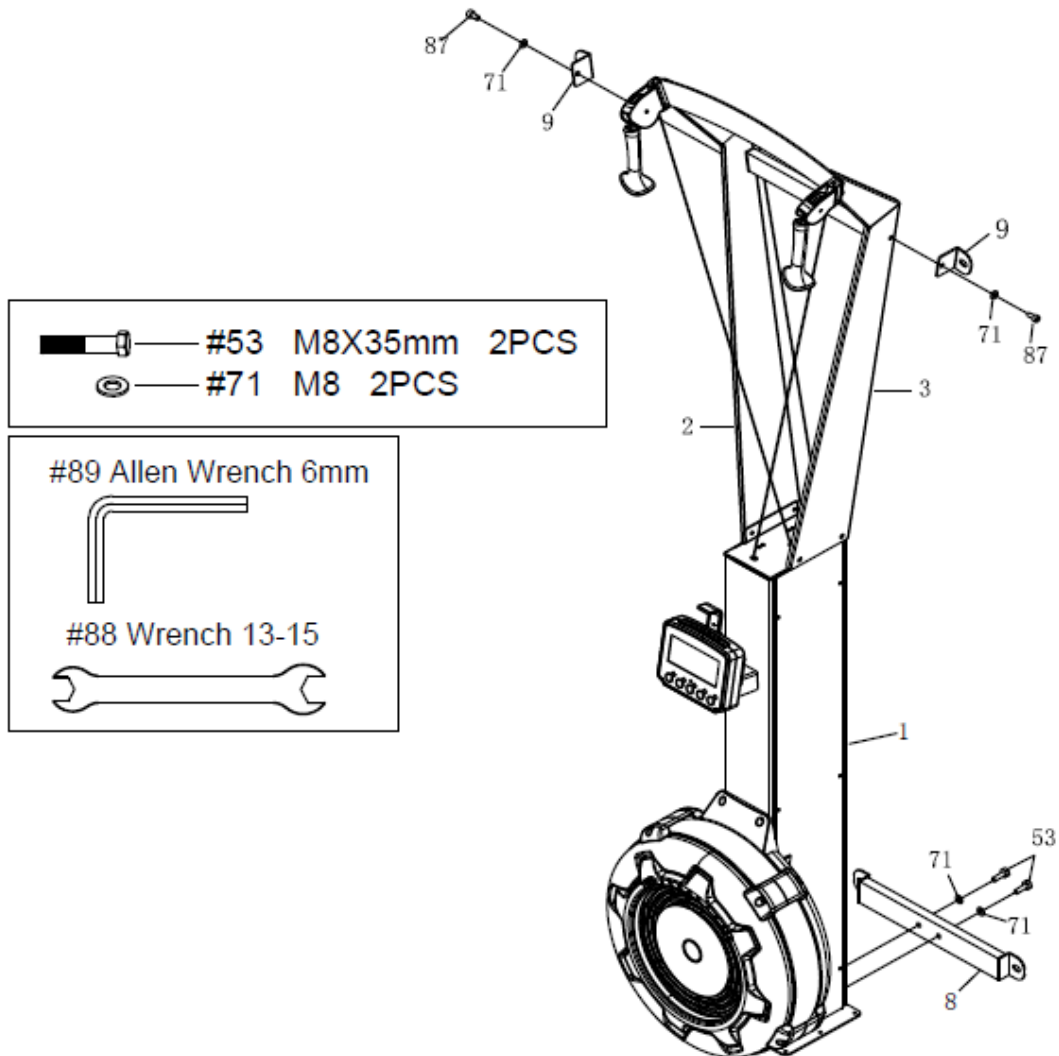

KROK 13

Place the machine against a solid wall. Make 4 marks at the location where the machine will be attached (8 and 9). Drill 4 holes at the holes.

KROK 14

Fasten to the wall with 4 screws (54) and washers (55).

WARNING: Use the screws according to the type of wall to which you want to attach the device. If you are unsure of the type of screws, consult a specialist.

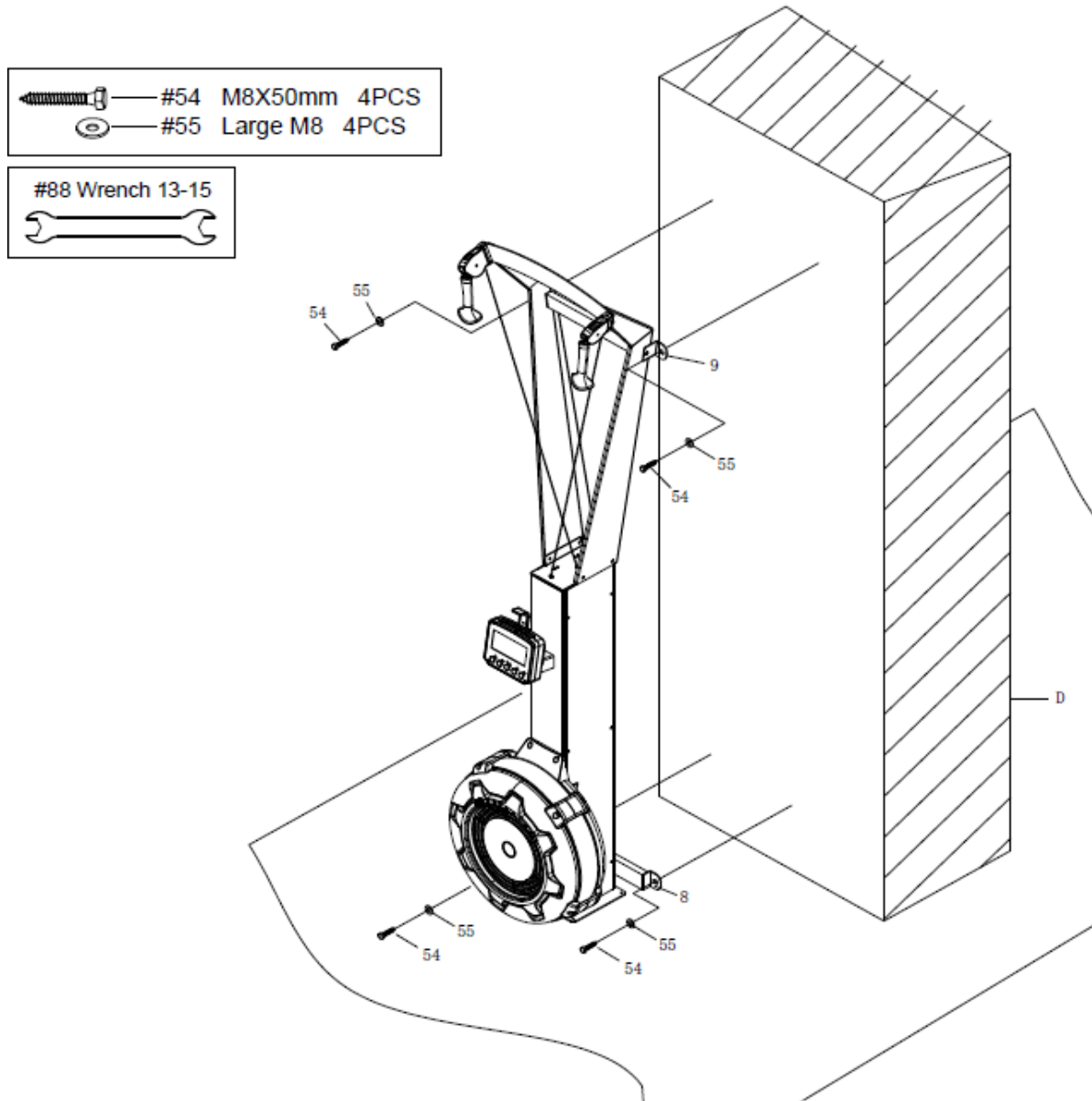

CONSOLE

The device uses a fan assembly to create resistance. We recommend using the console mainly to compare the results and track your progress.



GENERAL INFORMATION

Turn on: Move the handles to start the Quick start program or press any button to switch the console to standby.

Turn off: After 20 seconds in standby mode the console will turn off.

In Interval programs the console will turn off after 2 minutes of inactivity.

Other programs will turn of the console after 30 seconds of inactivity.

Unit change: Default units are KM. To change the units, press UP and DOWN. Display will show KM and MILE. Use UP and DOWN buttons to choose the unit and confirm ENTER.

Battery: Console is power by 2 C batteries. Batteries are located on the back of the console. Without batteries only Quick start program works

BUTTONS

SELECT	In main menu you can use the SELECT button to choose between programs. You can set the target DISTANCE, TIME, CALORIES, GAME or choose programs INTERVAL 20/10, 10/20, 10/10 NOTE: Default program is Quick start.
▲ UP	Increase value. Hold to increase the value faster.
▼ DOWN	Decrease value. Hold to decrease the value faster.
BACK	Press to return to previous program.

	Press the button after finishing the program to return to main menu.
ENTER/STOP	Choose selected program Hold the button for 3 seconds to reset all values and console. If the display backlight is off during exercise, press to turn on the backlight, press again to pause the program, and press again to start the program.

DISPLAY

NUMBER OF STROKES

Displays number of strokes per minute.

Semi-circle displays number of strokes. The more grids are displayed the higher stroke rate is.

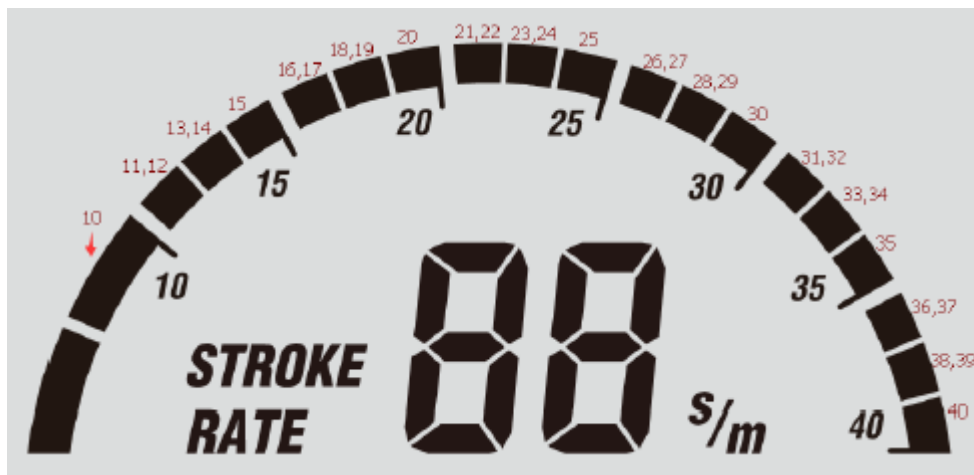

TIME&TIME/500m AVG

- Display time from 00:00 to 99:59 minutes
- Time is accumulated under any workout mode.
- Flashing 00:00 means that the countdown program can be set from 1:00 to 9:00 minutes
- Time is not saved in INTERVAL 10/10, setting range is 10-99
- Time/500m AVG is average time to reach the distance of 500 m.

TIME/500M

- Display from 00:00 to 99:59
- Time/500m AVG is average time to reach the distance of 500 m

WATTS AVG & PULSE

- Displays average power and pulse
- The average power is display from 0 to 999 watts.
- Pulse is displayed from 40 to 220 beats per minute. You need to wear a chest belt.

DISTANCE & DIST/30 MIN

- Display distance from 0 to 9999 meters. If the values is higher than 9999 meters, the counting starts from 0.
- Distance is calculated in any program.
- Flashing 500 means that the countdown program can be set from 500 to 9999 meters.
- Dis/30min is distance reach after 30 min during current pace.

CALORIES & CAL/HOUR

- Display burned calories from 0 to 999 cal.
- Flashing 10, means that the countdown program can be set from 10 to 990 cal.
- CAL/HOUR displays number of calories burned per hour.

CYCLE & WATTS

- Displayed only in INTERVAL program
- Flashing 8, means you can adjust the number of repetitions in INTERVAL program. Number of repetitions can be set from 1 to 99.
- Display shows power from 0 to 999 watts
- Watts display power during workout

PROGRAMS

Console contains 8 programs: QUICK START, TIME countdown, DISTANCE countdown, CALORIES countdown, GAME and INTERVAL programs 20/10, 10/20, 10/10

With SELECT button you can choose programs in this order: QUICK START – DISTANCE – TIME – CALORIES – GAME – 20/10 INTERVAL – 10/20 INTERVAL – 10/10 user interval

QUICK START PROGRAM

Pull the handle to start the program and counting the values.

Press STOP to stop counting. Pull the handle to start counting again. Hold STOP to reset values.

In QUICK START program and all countdown programs, press SELECT to display data including TIME & TIME/500m AVG.

For all 7 programs, press BACK to enter standby mode, or press ENTER/STOP button for 3 seconds to restart console. With SELECT you can choose the programs. With UP and DOWN you can adjust the value and confirm with ENTER/STOP button.

DISTANCE

During program the values is decreased from preset value.

The program will start when you pull the handles. When finished, WINNER appears, and sound signal will be played. Press the BACK button to return to the home screen.

TIME

During program the values is decreased from preset value.

The program will start when you pull the handles. When finished, WINNER appears, and sound signal will be played. Press the BACK button to return to the home screen.

CALORIES

During program the values is decreased from preset value. The program will start when you pull the handles. When finished, WINNER appears, and sound signal will be played. Press the BACK button to return to the home screen.

GAME PROGRAM

The program will start when you pull the handles. There is no need to enter any data. When the program is finished, the result is displayed, and sound signal will be played. Press BACK to return to the main menu.

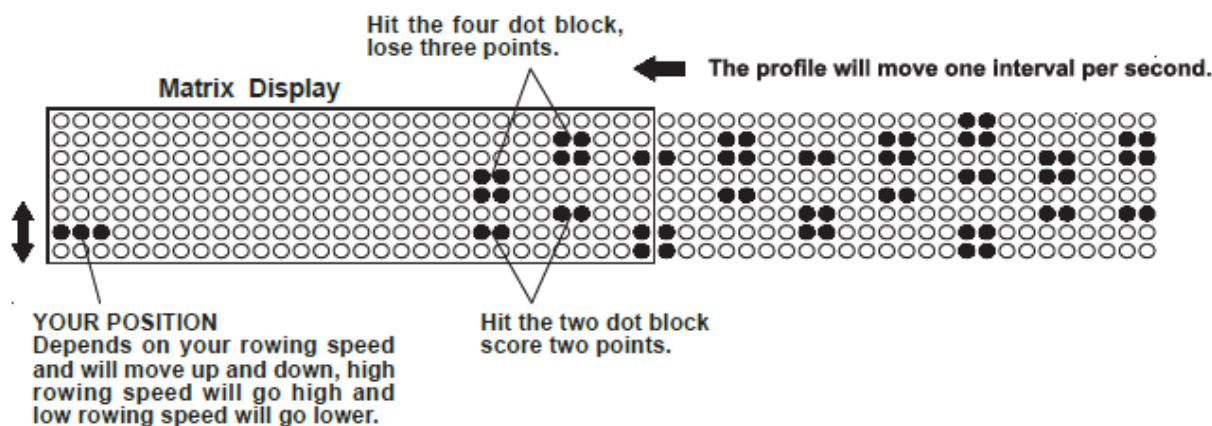

20/10 INTERVAL PROGRAM

On display will be flashing 8 for number of repetitions. 20 stands for 20 seconds of exercise and 10 stands for 10 seconds of rest. User can adjust the number of repetitions with UP a DOWN buttons from 1 to 99. The program will start when you pull the handles. When finished the sound signal will be played Press BACK to return to the main menu.

10/20 INTERVAL PROGRAM

On display will be flashing 8 for number of repetitions. 10 stands for 10 seconds of exercise and 20 stands for 20 seconds of rest. User can adjust the number of repetitions with UP a DOWN buttons from 1 to 99. The program will start when you pull the handles. When finished the sound signal will be played Press BACK to return to the main menu.

10/10 INTERVAL PROGRAM

On display will be flashing 8 for number of repetitions. User can adjust the number of repetitions of exercise and rest with UP a DOWN buttons from 1 to 99. The program will start when you pull the handles. When finished the sound signal will be played Press BACK to return to the main menu.

USE

USE AND TRAINING

SKI2000 offers great exercises for the whole body. Each downward pull exercises legs, arms, shoulders and torso, using body weight to accelerate the pull. Each thrust end with an extension of the arms along the sides with the knees partially bent.

SKI2000 allows you to train with two-pole movement, which is necessary for skate and classic skiing.

There is also a classic ski technique (shoulder alternation).

IMPORTANT SAFETY INSTRUCTIONS

Warning! The safety level of the machine can only be maintained if it is regularly inspected for damage and wear. Replacing wear parts as soon as it is found will ensure safety and performance, or leave the machine down for repair.

- Using this machine with worn or weakened parts (pulleys, ropes, bobbins) can cause injury to the user. If you are in doubt about the condition of any part, we recommend that you should replace them immediately. Use only original parts. Use of other parts may cause injury or poor performance of your equipment.
- SKI2000 with optional floor stand must be used on a stable, level surface.
- The SKI2000 mounted on the wall must be securely attached to the wall in the top and bottom brackets. Make sure that the mounting screws pass into a solid material such as wood or concrete and that you are using the correct components for the wall connection.

- Do not twist or cross ropes and avoid pulling the ropes to the point where they stop.
- Do not release the handles while they are in the extended position. Return the handles to the upper position before releasing them.
- Perform regular inspection and maintenance as recommended.
- Keep children away from SKI2000.

DOUBLE-POLE TECHNIQUE



Start with your arms wide apart at eye level. Arms should be bent, legs extended.



Hold the handles down with your abdomen and knees bent. Keep the bend so that the handles are relatively close to your face.



Finish the bend with slightly bent knees and shoulders that extend along the thighs.



Put your hands back and straighten your body to get back to the starting position.

CLASSIC CROSS-COUNTRY TECHNIQUE (ARM CENTER)



Start with one hand raised slightly bent.

Pull the upper arm down while gradually raising the lower arm.

Continue to alternate the shoulders and hold several bends in one arm, as this is a stronger position.

RESISTANCE

The fan (32) has inbuilt dampener (31) for resistance change. You can choose from level 1 (lower) to 9 (higher).

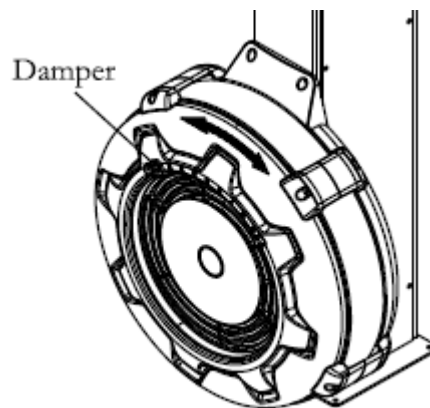

SMARTPHONE HOLDER

You can adjust the smartphone holder

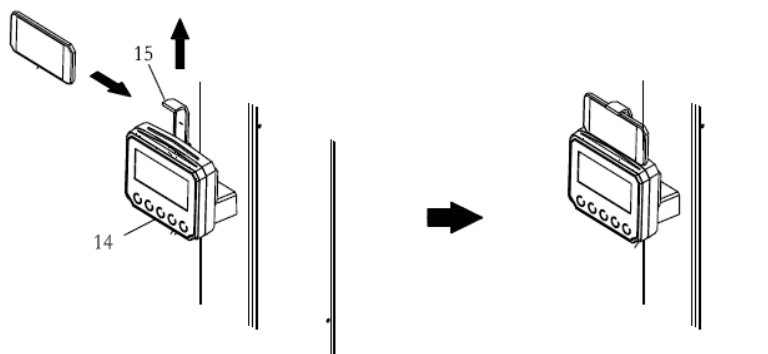

MAINTENANCE

The safety can only be ensured by regular maintenance and regular checks against wear and damage.

- Pull the handle and make sure it resists.
- Clean the revealed surface of cord pulley with an absorbent cloth.
- Check all bolts and nuts for tightness.
- Check the condition of the tow rope.

- Check the condition of the drive cord. Replace the drive cord if it is damaged or broken.
- Maintenance and operation of the machine is the responsibility of the machine owner.
- Damaged or worn parts must be replaced immediately. Until then, the device must not be used.
- Regularly clean the machine from sweat and dirt with a cloth.

STORAGE

- Keep the device in a clean, dry place.
- If you do not plan to use the device for an extended period of time, remove the battery from the console.
- Move the product by placing the product on the transport wheels as shown below.

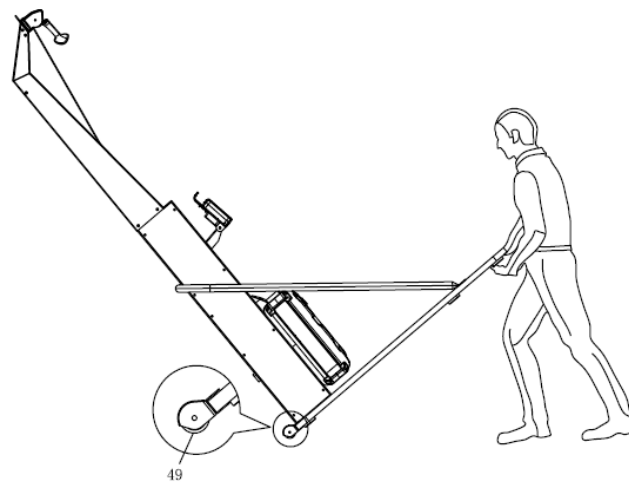
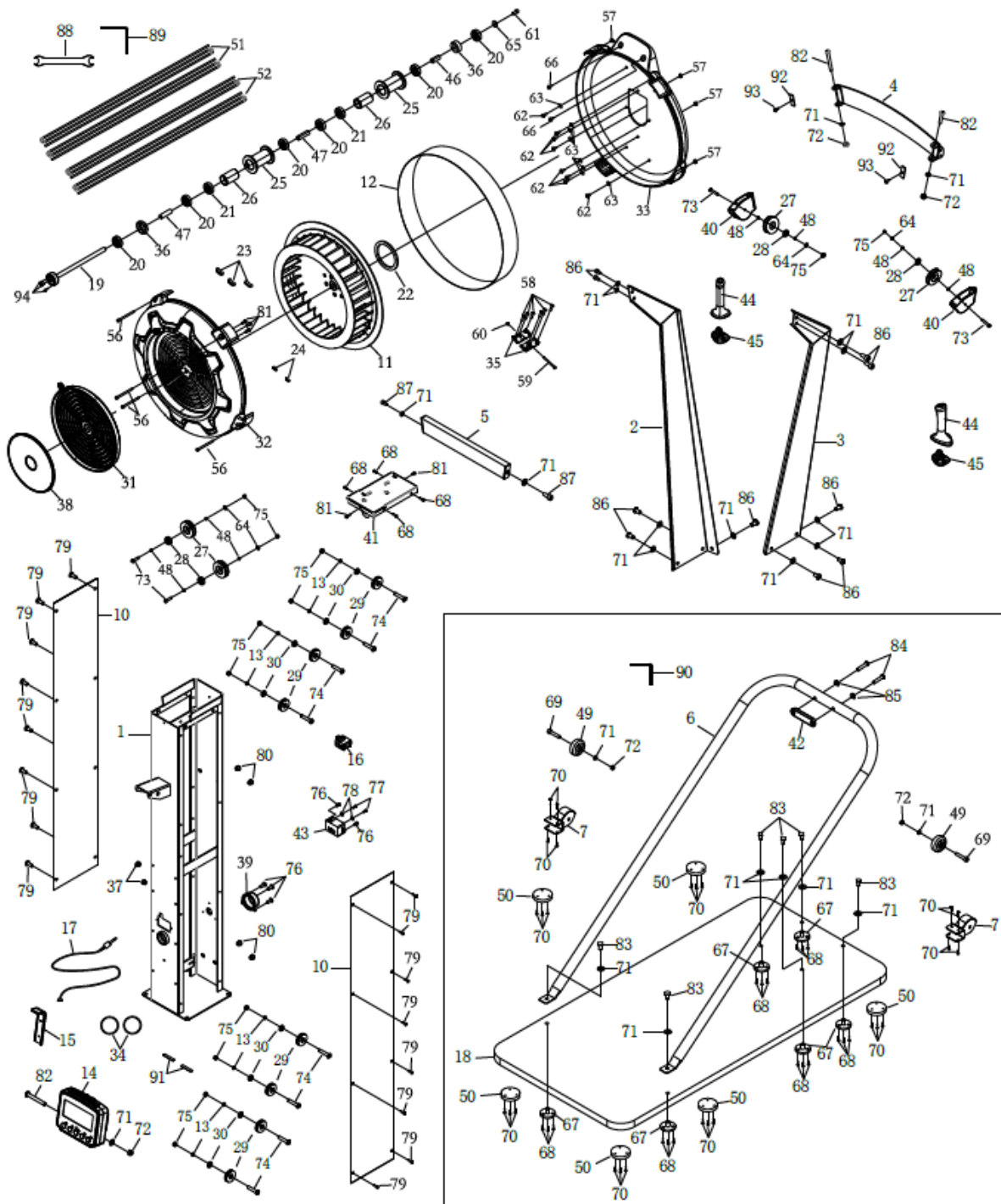

DIAGRAM – FREE STANDING



PARTS LIST – FREE STANDING

No.	Name	Qty.	No.	Name	Qty.
1	Main frame	1	38	Damper Cap	1
2	Left support arm	1	39	Pulley Cover	1
3	Right support arm	1	40	Pulley Holder	2
4	Top frame	1	41	Body upper cover	1
5	Connection rod	1	42	Washer	1
6	Support	1	43	Generator Base	1
7	Transport wheels cover	2	44	Handle	2
10	Body Cover (L/R)	2	45	Handle Plug	2
11	Fan	1	46	Short Spacer	1
12	Perforated Steel Mesh	1	47	Long Spacer	2
13	Console Pulley Spacer	8	48	Cord Pulley Spacer	8
14	Console Monitor	1	49	Transport Wheel	2
15	Cell Phone Bracket	1	50	Wooden Base Cushion	6
16	Generator	1	51	Bungee Cord	2
17	Sensor Cable	1	52	Drive Cord	2
18	Wooden Base	1	56	Screw M5x92 mm	4
19	Fan Axle	1	57	Nut M5	4
20	Bearings 6001RS	6	58	Screw ST4.2x6 mm	6
21	One Way Bearing	2	59	Screw M4x45 mm	1
22	Magnet	1	60	Nut M4	1
23	Balance Weight	3	61	Screw M6x12mm	1
24	Small Balance Weight	2	62	Screw M6x10mm	8
25	Cord Pulley	2	63	Washer M6	8
26	Pulley Spacer	2	64	Flat washer M6	4
27	Cord Pulley	4	65	Washer $\varnothing 16 \times \varnothing 6.2 \times 1.5$ mm	1
28	Bearing 6000ZZ	4	66	Screw M6x16 mm	2
29	Console Pulley	8	67	Nut M8	6
30	Bearing 606ZZ	8	68	Screw ST4.2x16 mm	22
31	Damper	1	69	Screw M8x40 mm	2
32	Upper Fan Shroud	1	70	Screw ST4.2x25 mm	26
33	Bottom Fan Shroud	1	71	Washer M8	25
34	Rubber band	2	72	Nut M8	5
35	Steel Plate	2	73	Screw M6x35 mm	4
36	Bearings 6001	2	74	Screw M6x20 mm	8
37	Cable Plug	2	75	Nut M6	12

76	Screw ST4.2x13 mm	5	86	Screw M8x12mm	10
77	Screw ST3.5x12 mm	2	87	Screw M8x15mm	2
78	Washer Φ 12x Φ 3.5x1.0 mm	2	88	Wrench	1
79	Screw M5x8 mm	16	89	Allen key 6 mm	1
80	Nut M8	4	90	Allen key 5 mm	1
81	Screw ST4.2x16 mm	5	91	EVA Single Glue	2
82	Screw M8x75 mm	3	92	Rubber Cushion	2
83	Screw M8x30 mm	6	93	Screw M5x8 mm	2
84	Screw M8x50 mm	2	94	Screw M4x12mm	3
85	Arc washer M8	2			

DIAGRAM – WALL MOUNTED

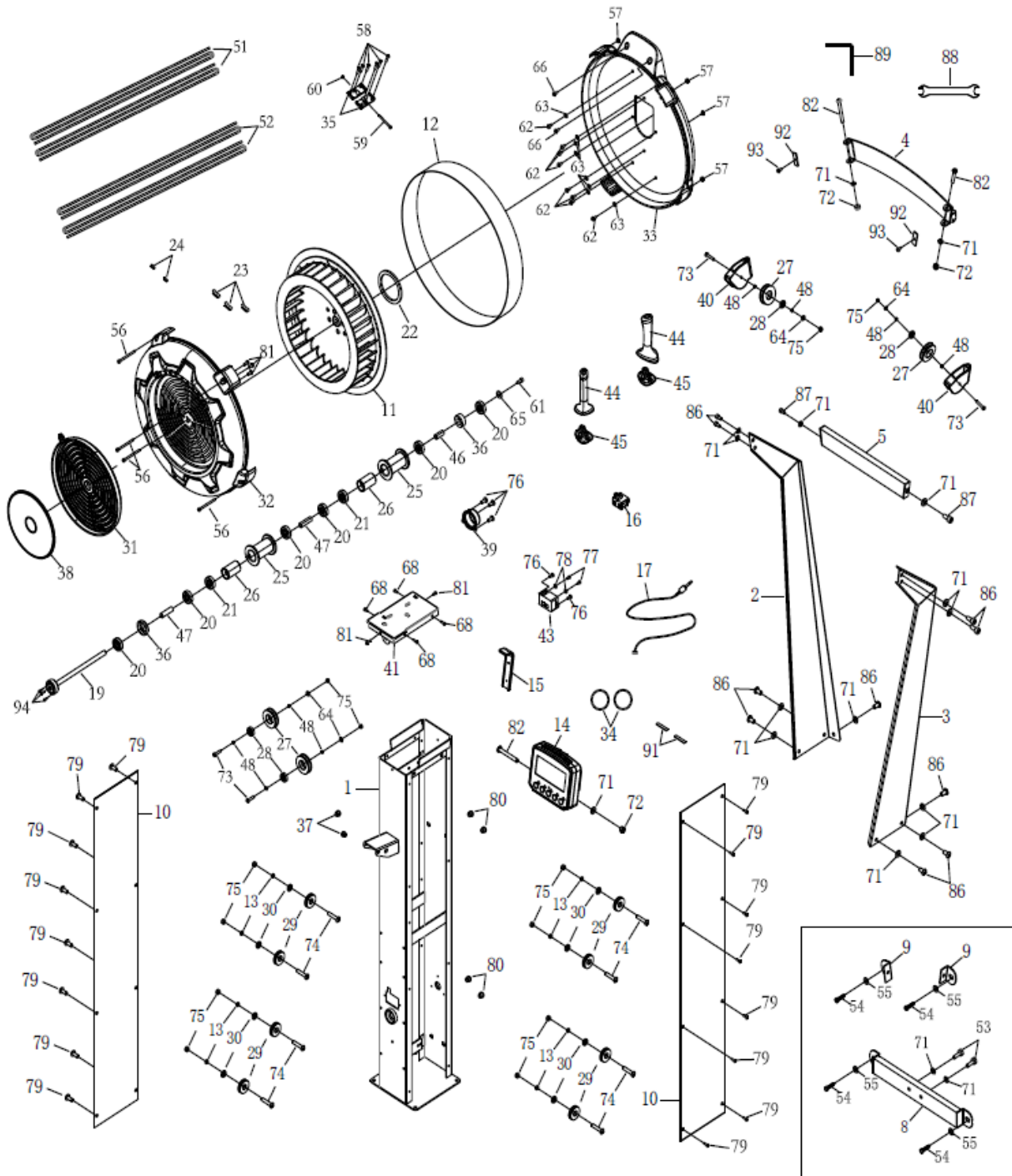

PARTS LIST – WALL ASSEMBLY

No.	Name	Qty.	No.	Name	Qty.
1	Main frame	1	38	Damper Cap	1
2	Left support arm	1	39	Pulley Cover	1
3	Right support arm	1	40	Pulley Holder	2
4	Top frame	1	41	Body upper cover	1
5	Connection rod	1	43	Generator Base	1
8	Lower Wall Mounting Bracket	1	44	Handle	2
9	Upper Wall Mounting Bracket	2	45	Handle Plug	2
10	Body Cover (L/R)	2	46	Short Spacer	1
11	Fan	1	47	Long Spacer	2
12	Perforated Steel Mesh	1	48	Cord Pulley Spacer	8
13	Console Pulley Spacer	8	51	Bungee Cord	2
14	Console Monitor	1	52	Drive Cord	2
15	Cell Phone Bracket	1	53	Screw M8x 35 mm	2
16	Generator	1	54	Screw ST4,2x6 mm	4
17	Sensor Cable	1	55	Washer $\Phi 22 \times \Phi 9 \times 2.0$ mm	4
18	Wooden Base	1	56	Screw M5x92 mm	4
19	Fan Axle	1	57	Nut M5	4
20	Bearings 6001RS	6	58	Screw ST4.2x6 mm	6
21	One Way Bearing	2	59	Screw M4x45 mm	1
22	Magnet	1	60	Nut M4	1
23	Balance Weight	3	61	Screw M6x12mm	1
24	Small Balance Weight	2	62	Screw M6x10mm	8
25	Cord Pulley	2	63	Washer M6	8
26	Pulley Spacer	2	64	Flat washer M6	4
27	Cord Pulley	4	65	Washer $\phi 16 \times \phi 6.2 \times 1.5$ mm	1
28	Bearing 6000ZZ	4	66	Screw M6x16 mm	2
29	Console Pulley	8	68	Screw ST4.2x16 mm	22
30	Bearing 606ZZ	8	71	Washer M8	25
31	Damper	1	72	Nut M8	5
32	Upper Fan Shroud	1	73	Screw M6x35 mm	4
33	Bottom Fan Shroud	1	74	Screw M6x20 mm	8
34	Rubber band	2	75	Nut M6	12
35	Steel Plate	2	76	Screw ST4.2x13 mm	5
36	Bearings 6001	2	77	Screw ST3.5x12 mm	2
37	Cable Plug	2	78	Washer $\Phi 12 \times \Phi 3.5 \times 1.0$ mm	2

79	Screw M5x8 mm	16	89	Allen key 6 mm	1
80	Nut M8	4	91	EVA Single Glue	2
81	Screw ST4.2x16 mm	5	92	Rubber Cushion	2
82	Screw M8x75 mm	3	93	Screw M5x8 mm	2
86	Screw M8x12mm	10	94	Screw M4x12mm	3
87	Screw M8x15mm	2			
88	Wrench	1			

ENVIRONMENT PROTECTION

After the product lifespan expired or if the possible repairing is uneconomic, dispose it according to the local laws and environmentally friendly in the nearest scrapyard.

By proper disposal you will protect the environment and natural sources. Moreover, you can help protect human health. If you are not sure in correct disposing, ask local authorities to avoid law violation or sanctions.

Don't put the batteries among house waste but hand them in to the recycling place.

TERMS AND CONDITIONS OF WARRANTY, WARRANTY CLAIMS

General Conditions of Warranty and Definition of Terms

All Warranty Conditions stated hereunder determine Warranty Coverage and Warranty Claim Procedure. Conditions of Warranty and Warranty Claims are governed by Act No. 89/2012 Coll. Civil Code, and Act No. 634/1992 Coll., Consumer Protection, as amended, also in cases that are not specified by these Warranty rules.

The seller is SEVEN SPORT s.r.o. with its registered office in Borivojova Street 35/878, Prague 13000, Company Registration Number: 26847264, registered in the Trade Register at Regional Court in Prague, Section C, Insert No. 116888.

According to valid legal regulations it depends whether the Buyer is the End Customer or not.

“The Buyer who is the End Customer” or simply the “End Customer” is the legal entity that does not conclude and execute the Contract in order to run or promote his own trade or business activities.

“The Buyer who is not the End Customer” is a Businessman that buys Goods or uses services for the purpose of using the Goods or services for his own business activities. The Buyer conforms to the General Purchase Agreement and business conditions.

These Conditions of Warranty and Warranty Claims are an integral part of every Purchase Agreement made between the Seller and the Buyer. All Warranty Conditions are valid and binding, unless otherwise specified in the Purchase Agreement, in the Amendment to this Contract or in another written agreement.

Warranty Conditions

Warranty Period

The Seller provides the Buyer a 24 months Warranty for Goods Quality, unless otherwise specified in the Certificate of Warranty, Invoice, Bill of Delivery or other documents related to the Goods. The legal warranty period provided to the Consumer is not affected.

By the Warranty for Goods Quality, the Seller guarantees that the delivered Goods shall be, for a certain period of time, suitable for regular or contracted use, and that the Goods shall maintain its regular or contracted features.

The Warranty does not cover defects resulting from (if applicable):

- User's fault, i.e. product damage caused by unqualified repair work, improper assembly, insufficient insertion of seat post into frame, insufficient tightening of pedals and cranks
- Improper maintenance
- Mechanical damages
- Regular use (e.g. wearing out of rubber and plastic parts, moving mechanisms, joints, wear of brake pads/blocks, chain, tires, cassette/multi wheel etc.)
- Unavoidable event, natural disaster
- Adjustments made by unqualified person
- Improper maintenance, improper placement, damages caused by low or high temperature, water, inappropriate pressure, shocks, intentional changes in design or construction etc.

Warranty Claim Procedure

The Buyer is obliged to check the Goods delivered by the Seller immediately after taking the responsibility for the Goods and its damages, i.e. immediately after its delivery. The Buyer must check the Goods so that he discovers all the defects that can be discovered by such check.

When making a Warranty Claim the Buyer is obliged, on request of the Seller, to prove the purchase and validity of the claim by the Invoice or Bill of Delivery that includes the product's serial number, or eventually by the documents without the serial number. If the Buyer does not prove the validity of the Warranty Claim by these documents, the Seller has the right to reject the Warranty Claim.

If the Buyer gives notice of a defect that is not covered by the Warranty (e.g. in the case that the Warranty Conditions were not fulfilled or in the case of reporting the defect by mistake etc.), the Seller is eligible to require a compensation for all the costs arising from the repair. The cost shall be calculated according to the valid price list of services and transport costs.

If the Seller finds out (by testing) that the product is not damaged, the Warranty Claim is not accepted. The Seller reserves the right to claim a compensation for costs arising from the false Warranty Claim.

In case the Buyer makes a claim about the Goods that is legally covered by the Warranty provided by the Seller, the Seller shall fix the reported defects by means of repair or by the exchange of the damaged part or product for a new one. Based on the agreement of the Buyer, the Seller has the right to exchange the defected Goods for a fully compatible Goods of the same or better technical characteristics. The Seller is entitled to choose the form of the Warranty Claim Procedures described in this paragraph.

The Seller shall settle the Warranty Claim within 30 days after the delivery of the defective Goods, unless a longer period has been agreed upon. The day when the repaired or exchanged Goods is handed over to the Buyer is considered to be the day of the Warranty Claim settlement. When the Seller is not able to settle the Warranty Claim within the agreed period due to the specific nature of the Goods defect, he and the Buyer shall make an agreement about an alternative solution. In case such agreement is not made, the Seller is obliged to provide the Buyer with a financial compensation in the form of a refund.



SEVEN SPORT s.r.o.

Registered Office: Borivojova 35/878, 130 00 Praha 3, Czech Republic
Headquarters: Delnicka 957, 749 01 Vitkov, Czech Republic
Warranty & Service Centre: Cermenska 486, 749 01 Vitkov, Czech Republic
CRN: 26847264
VAT ID: CZ26847264
Phone: +420 556 300 970
E-mail: eshop@insportline.cz
reklamace@insportline.cz
servis@insportline.cz
Web: www.insportline.cz

SK

INSPORTLIN s.r.o.

Headquarters, Warranty & Service centre: Elektricka 6471, 911 01 Trencin, Slovakia
CRN: 36311723
VAT ID: SK2020177082
Phone: +421(0)326 526 701
E-mail: objednavky@insportline.sk
reklamacie@insportline.sk
servis@insportline.sk
Web: www.insportline.sk

Date of Sale:

Stamp and Signature of Seller: